



4289

# STANDARD MEMORY INTERFACE

- Direct Interface to all Standard Memories
- Allows Read and Write Program Memory
- Single Package Equivalent of 4008/4009
- TTL Compatible Address, Chip Select, Program Memory Data Lines
- 40 Pin Dual In-Line Package
- Standard Operating Temperature Range of 0° to 70° C
- Also Available With -40° to +85° C Operating Range

The 4289 standard memory interface and I/O interface enables the CPU devices to utilize standard memory components as program data memory. Notably, PROMs (4702A), RAMs (2102) and ROMs can be arranged in a memory array to facilitate system development. Programs generated using the 4289 interface can be committed to MCS-40™ ROMs (4308 and 4001) with no change to software.

The 4289 also contains a 4 bit bi-directional I/O port and necessary steering logic to multiplex a host of I/O sources to the CPU. The Read and Write Program Memory instruction allows the user to store data and modify program memory. The device directly addresses 4K of program memory. The address is obtained sequentially during A1-A3 states of an instruction cycle. The eight bit instruction is presented to the CPU during M1 and M2 states of the instruction cycle via the four bit data bus.

The 4289 stores the SRC instruction operand as an I/O address and responds to the ROM I/O instructions (WRR and RDR) by reading or writing data to and from the processor and 4289 I/O bus.

## BLOCK DIAGRAM

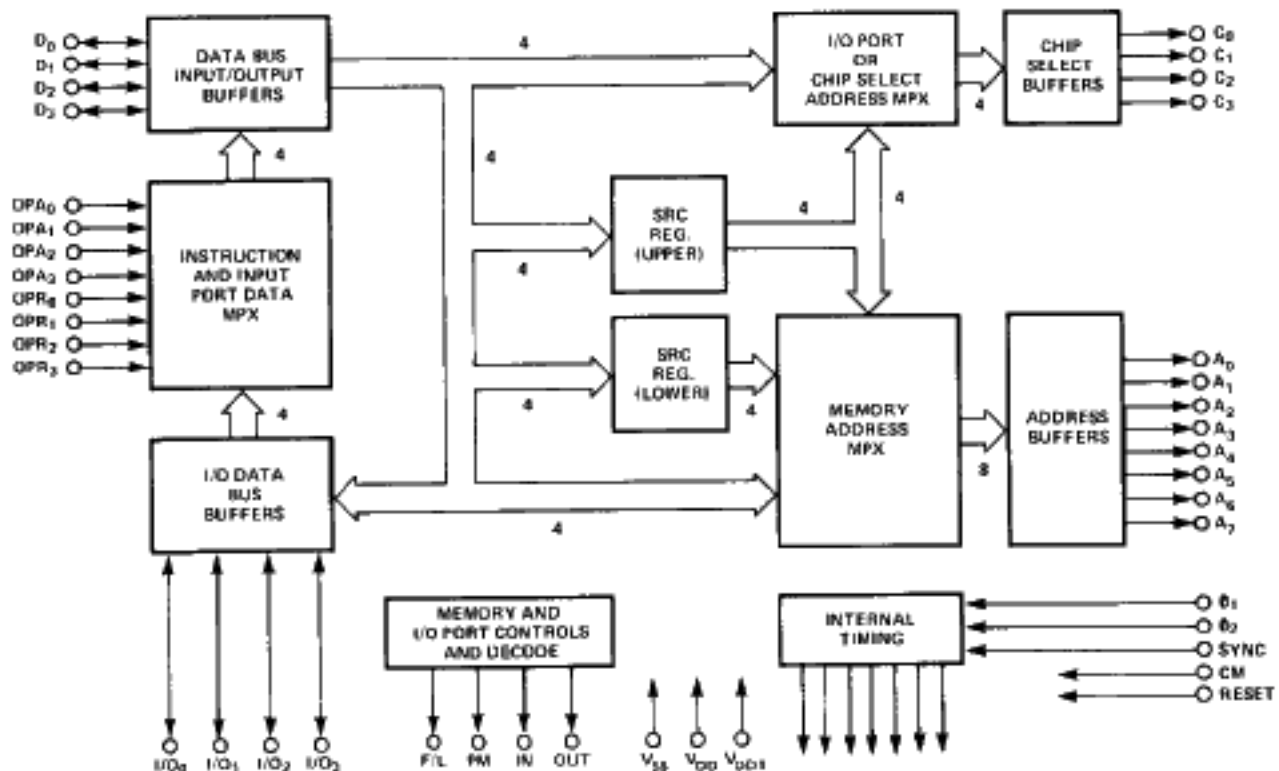

MCS-4/40