

OKI semiconductor

MSM27256

32,768-Word x 8-Bit UV EPROM

GENERAL DESCRIPTION

The MSM27256 is a 32,768-word x 8-bit ultraviolet erasable and electrically programmable read-only memory. The MSM27256 is manufactured by the N channel double silicon gate MOS technology and is contained in the 28-pin package.

FEATURES

- +5V single power supply
- 32,768-word x 8-bit configuration
- Access time:
 - MAX 150 ns (MSM27256-15)
 - MAX 200 ns (MSM27256-20)
 - MAX 250 ns (MSM27256-25)
- Power consumption
 - MAX525 mW (during operation)
 - MAX184 mW (during standby)
- Completely static operation
- INPUT/OUTPUT TTL compatible (three state output)

PIN CONFIGURATION (TOP VIEW)

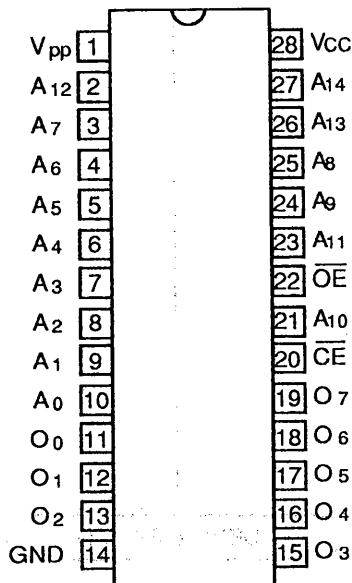

FUNCTIONAL BLOCK DIAGRAM

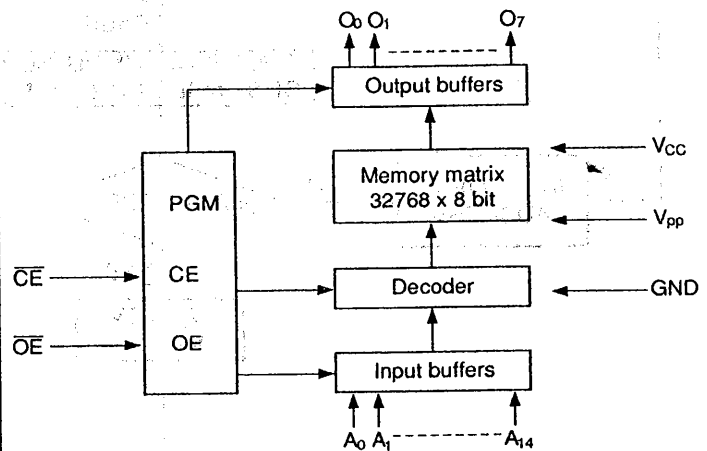

This specification may be changed without notification.

TRUTH TABLE

Mode \ Pins	CE (20)	OE (22)	V _{pp} (1)	V _{CC} (28)	Outputs
Read	V _{IL}	V _{IL}	+5V	+5V	D _{OUT}
Output Disable	V _{IL}	V _{IH}	+5V	+5V	High impedance
Standby	V _{IH}	—	+5V	+5V	High impedance
Program	V _{IL}	V _{IH}	+12.5V	+6V	D _{IN}
Program Verify	V _{IH}	V _{IL}	+12.5V	+6V	D _{OUT}
Program Inhibit	V _{IH}	V _{IH}	+12.5V	+6V	High impedance

—: Can be either V_{IL} or V_{IH}

**ELECTRICAL CHARACTERISTICS
ABSOLUTE MAXIMUM RATINGS**

Rating	Symbol	Conditions	Value	Unit
Temperature Under Bias	T _a	————	0 ~ 70	°C
Storage Temperature	T _{stg}	————	-55 ~ 125	°C
Input Voltage	V _{IN}	————	-0.6 ~ 13.5	V
Output voltage	V _{OUT}	————	-0.6 ~ 7	V
V _{CC} Supply Voltage	V _{CC}	————	-0.6 ~ 7	V
Program Voltage	V _{pp}	————	-0.6 ~ 14	V

The voltage referenced to GND.

Note: Permanent device damage may occur if ABSOLUTE MAXIMUM RATINGS are exceeded. Functional operation should be restricted to the conditions as detailed in the operational sections of this data sheet. Exposure to absolute maximum rating conditions for extended periods may affect device reliability.

**READ OPERATION
RECOMMENDED OPERATING CONDITIONS**

(T_a = 0 ~ 70°C)

Parameter	Symbol	Conditions	Value			Unit
			Min.	Typ.	Max.	
Supply Voltage	V _{CC}	V _{CC} = 5V ± 5% V _{PP} = V _{CC}	4.75	5.0	5.25	V
V _{pp} Voltage	V _{pp}		4.75	5.0	5.25	V
"H" Level Input Voltage	V _{IH}		2.0	—	6.25	V
"L" Level Input Voltage	V _{IL}		-0.1	—	0.8	V

The voltage referenced to GND.

DC CHARACTERISTICS

($V_{CC} = 5V \pm 5\%$, $V_{pp} = V_{CC}$, $T_a = 0 \sim 70^\circ C$)

Parameter	Symbol	Conditions	MSM27256			Unit	Notes
			Min.	Typ.	Max.		
Input Leakage Current	I_{LI}	$V_{IN} = 5.25V$	-	-	10	μA	
Output Leakage Current	I_{LO}	$V_{OUT} = 5.25V$	-	-	10	μA	
V_{CC} Power Current (Standby)	I_{CC1}	$\overline{CE} = V_{IH}$	-	-	35	mA	
V_{CC} Power Current (Operation)	I_{CC2}	$\overline{CE} = V_{IL}$	-	-	100	mA	
Program Power Current	I_{pp1}	$V_{pp} = V_{CC}$	-	-	5	mA	
Input Voltage "H" Level	V_{IH}	-	2.0	-	$V_{CC}+1$	V	
Input Voltage "L" Level	V_{IL}	-	-0.1	-	0.8	V	
Output Voltage "H" Level	V_{OH}	$I_{OH} = -400 \mu A$	2.4	-	-	V	
Output Voltage "L" Level	V_{OL}	$I_{OL} = 2.1 \text{ mA}$	-	-	0.45	V	

AC CHARACTERISTICS

($V_{CC} = 5V \pm 5\%$, $V_{pp} = V_{CC}$, $T_a = 0 \sim 70^\circ C$)

Parameter	Symbol	Conditions	27256-15		27256-20		27256-25		Unit	Notes
			Min.	Max.	Min.	Max.	Min.	Max.		
Address Access Time	t_{ACC}	$\overline{CE} = \overline{OE} = V_{IL}$	-	150	-	200	-	250	ns	
\overline{CE} Access Time	t_{CE}	$\overline{OE} = V_{IL}$	-	150	-	200	-	250	ns	
\overline{OE} Access Time	t_{OE}	$\overline{CE} = V_{IL}$	-	60	-	70	-	100	ns	
Output Disable Time	t_{DF}	$\overline{CE} = V_{IL}$	0	50	0	55	0	60	ns	

Measurement Conditions

- Input pulse level 0.45V and 2.4V
- Input timing reference level 0.8V and 2.0V
- Output load 1 TTL GATE + 100 pF
- Output timing reference level 0.8V and 2.0V

TIME CHART

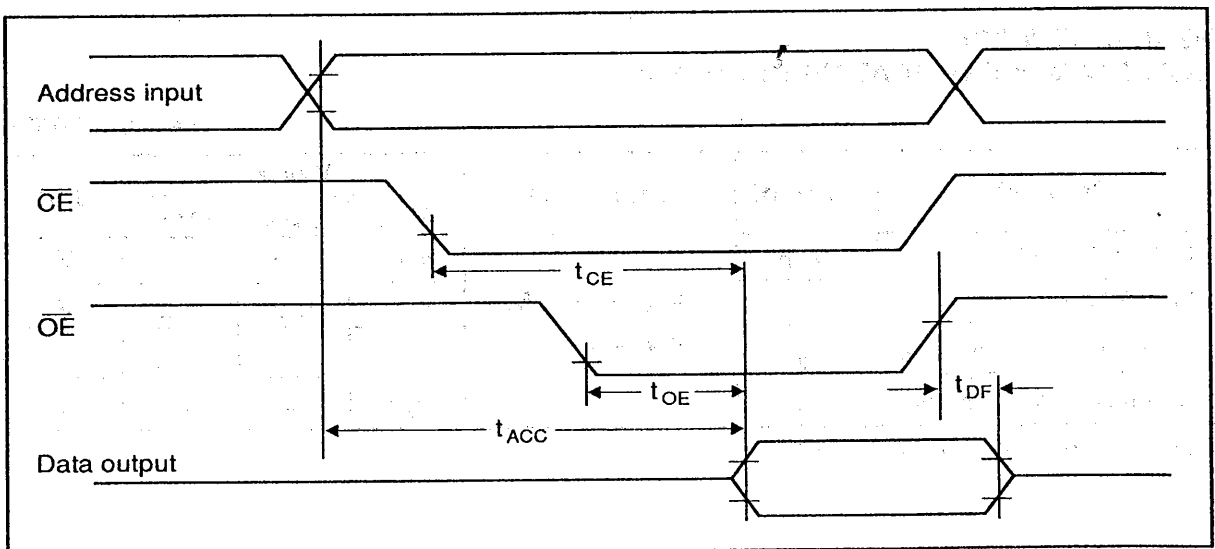

**PROGRAMMING OPERATION
DC CHARACTERISTICS**

($V_{CC} = 5.75V \sim 6.5V$, $V_{pp} = 12.5V \pm 0.5V$, $T_a = 25^\circ C \pm 5^\circ C$)

Parameter	Symbol	Conditions	MSM27256			Unit	Notes
			Min.	Typ.	Max.		
Input Leakage Current	I_{LI}	$V_{IN} = 5.25V$	-	-	10	μA	
V_{pp} Power Current	I_{pp2}	$\overline{CE} = V_{IL}, \overline{OE} = V_{IH}$	-	-	50	mA	
V_{CC} Power Current	I_{CC}	-	-	-	100	mA	
Input Voltage "H" Level	V_{IH}	-	2.0	-	$V_{CC}+1$	V	
Input Voltage "L" Level	V_{IL}	-	-0.1	-	0.8	V	
Output Voltage "H" Level	V_{OH}	$I_{OH} = -400 \mu A$	2.4	-	-	V	
Output Voltage "L" Level	V_{OL}	$I_{OL} = 2.1 mA$	-	-	0.45	V	

AC CHARACTERISTICS

($V_{CC} = 5.75V \sim 6.5V$, $V_{pp} = 12.5V \pm 0.5V$, $T_a = 25^\circ C \pm 5^\circ C$)

Parameter	Symbol	Conditions	MSM27256			Unit	Notes
			Min.	Typ.	Max.		
Address Set-up Time	t_{AS}	-	2	-	-	μS	
\overline{OE} Set-up Time	t_{OES}	-	2	-	-	μS	
Data Set-up Time	t_{DS}	-	2	-	-	μS	
Address Hold Time	t_{AH}	-	0	-	-	μS	
Data Hold Time	t_{DH}	-	2	-	-	μS	
Output Enable to Output Float Delay	t_{DFP}	-	0	-	130	ns	
V_{pp} Power Set-up Time	t_{VS}	-	2	-	-	μS	
\overline{CE} Initial Program Pulse Width	t_{PW}	$V_{CC} = 6V \pm 0.25V$	0.95	1.0	1.05	mS	
\overline{CE} Program Pulse Width	t_{PW}	$V_{CC} = 6.25V \pm 0.25V$	95	100	105	μS	
\overline{CE} Overprogram Pulse Width	t_{OPW}	$V_{CC} = 6V \pm 0.25V$	2.85	-	78.75	ms	
Data Valid from \overline{OE}	t_{OE}	-	-	-	150	ns	

7

TIME CHART

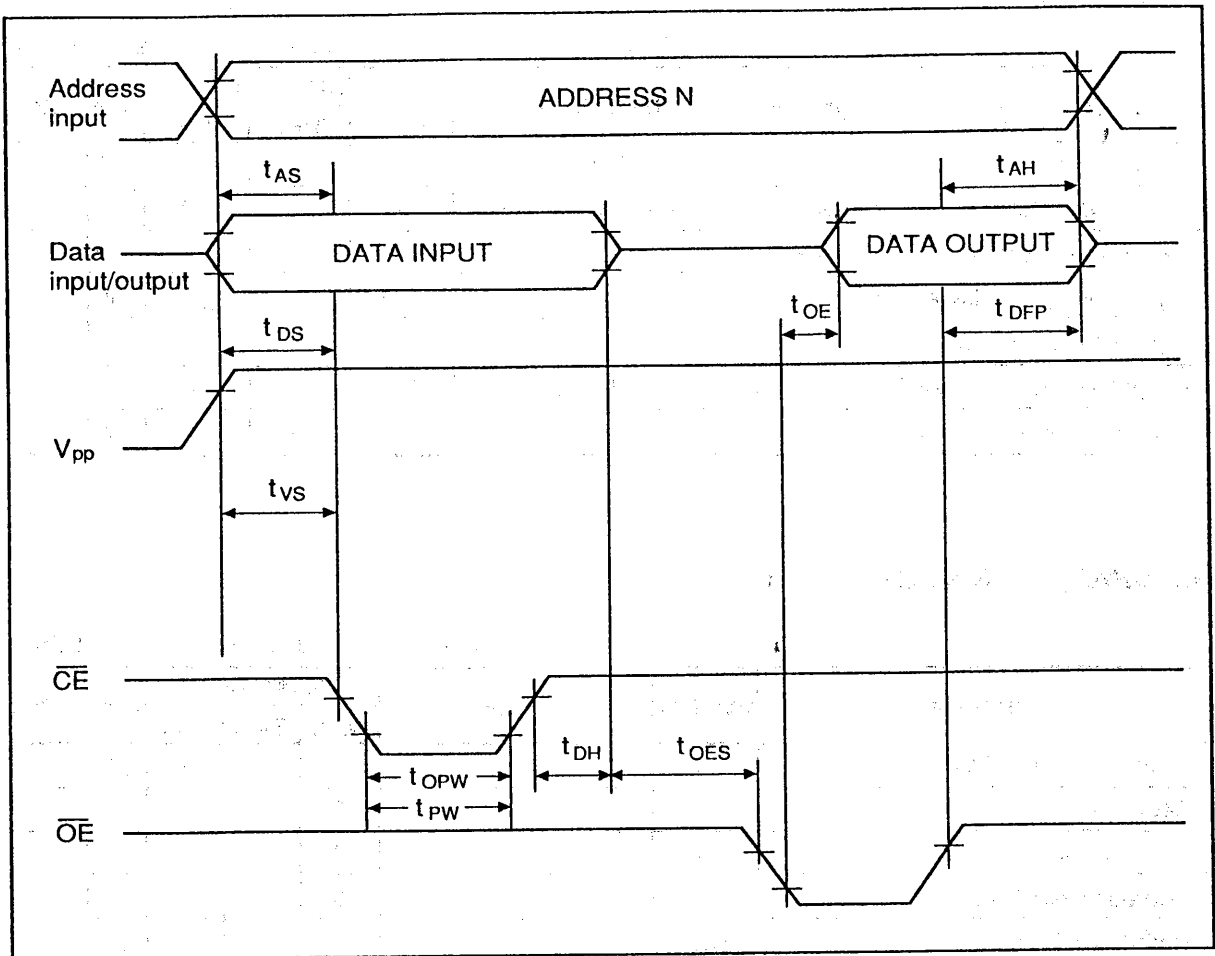

CAPACITANCE

(T_a = 25°C, f = 1 MHz, V_{cc} = 5V)

Parameter	Symbol	Conditions	Min.	Typ.	Max.	Unit
Input Capacitance	C _{IN}	V _{IN} = 0V	—	4	6	pF
Output Capacitance	C _{OUT}	V _{OUT} = 0V	—	8	12	pF

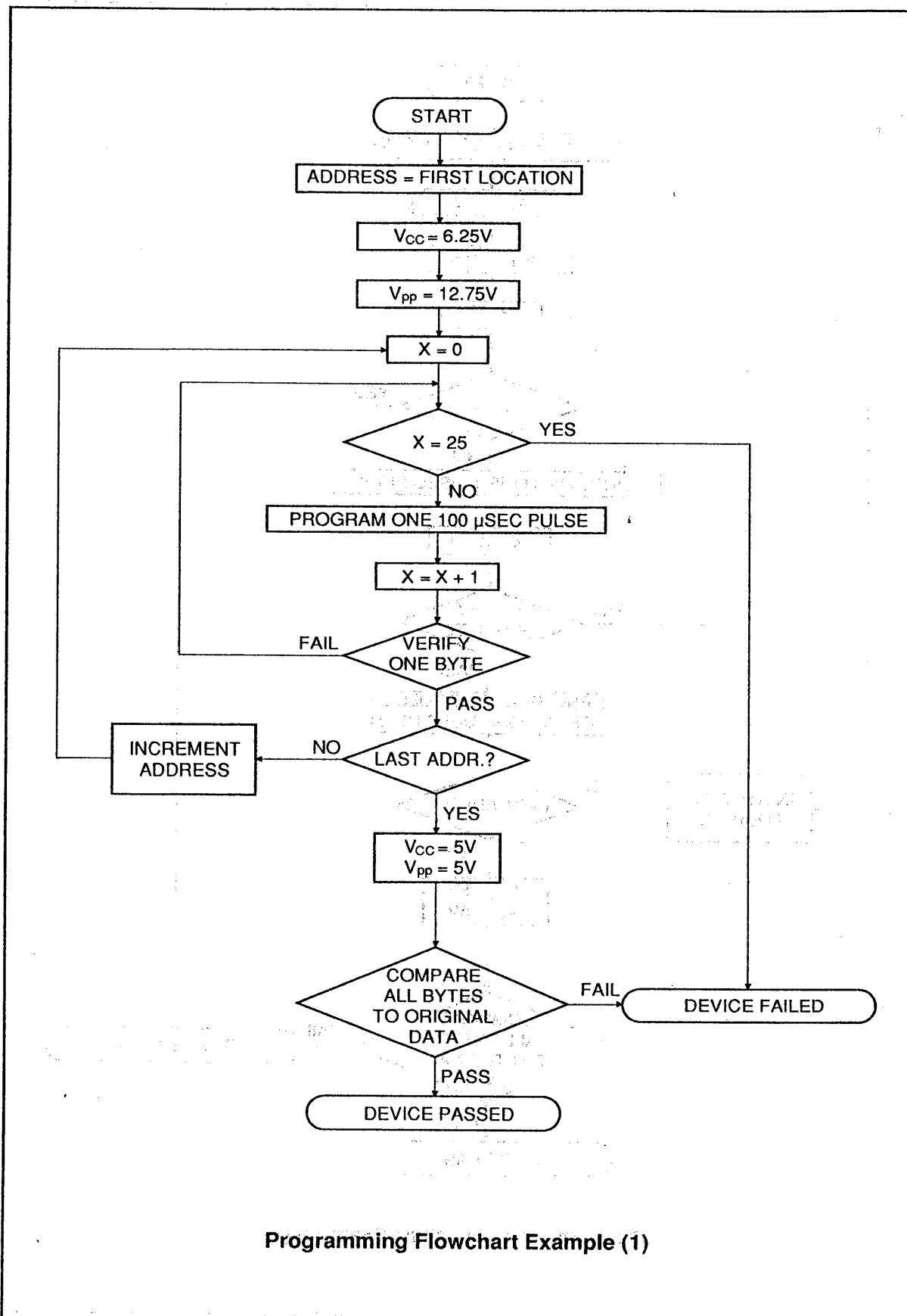

Programming Flowchart Example (1)

7

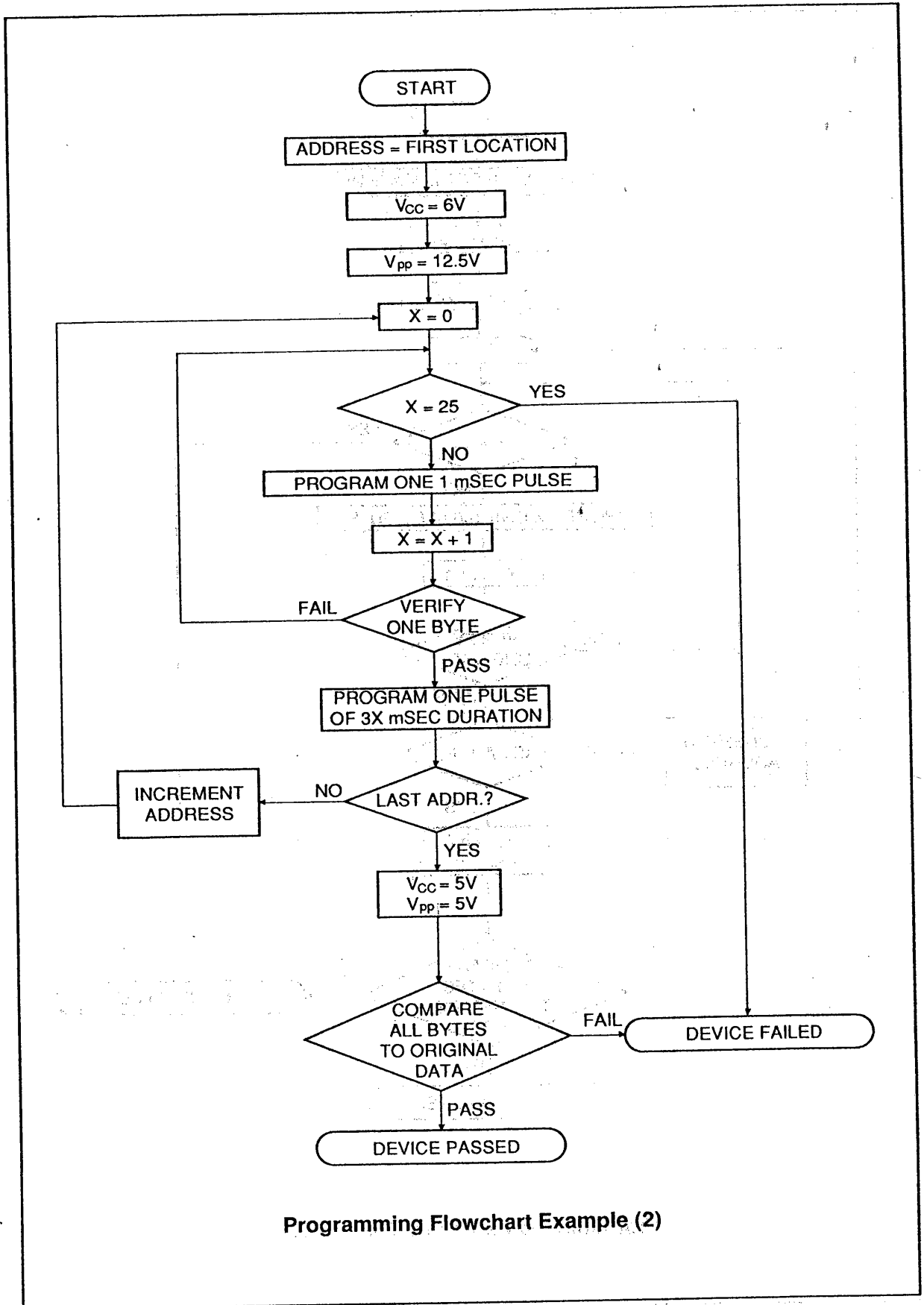

Programming Flowchart Example (2)