

FEATURES

- 10 years minimum data retention in the absence of external power
- Data is automatically protected during power loss
- Directly replaces 2K x 8 volatile static RAM or EEPROM
- Unlimited write cycles
- Low-power CMOS
- JEDEC standard 24-pin DIP package
- Read and write access times as fast as 100 ns
- Full $\pm 10\%$ operating range
- Optional industrial temperature range of -40°C to $+85^{\circ}\text{C}$, designated IND

PIN ASSIGNMENT

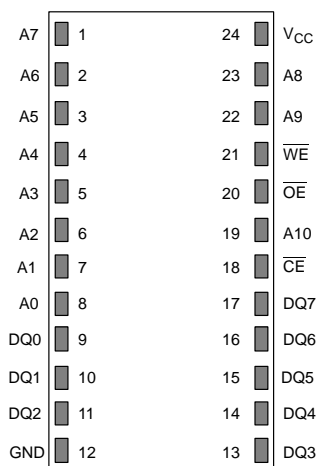

24-PIN ENCAPSULATED PACKAGE
720 MIL EXTENDED

PIN DESCRIPTION

A0–A10	– Address Inputs
DQ0–DQ7	– Data In/Data Out
$\overline{\text{CE}}$	– Chip Enable
$\overline{\text{WE}}$	– Write Enable
$\overline{\text{OE}}$	– Output Enable
V _{CC}	– Power (+5V)
GND	– Ground

DESCRIPTION

The DS1220Y 16K Nonvolatile SRAM is a 16,384-bit, fully static, nonvolatile RAM organized as 2048 words by 8 bits. Each NV SRAM has a self-contained lithium energy source and control circuitry which constantly monitors V_{CC} for an out-of-tolerance condition. When such a condition occurs, the lithium energy source is automatically switched on and write protection is unconditionally enabled to prevent data corruption. The NV SRAM can be used in place of existing 2K x 8 SRAMs

directly conforming to the popular byte-wide 24-pin DIP standard. The DS1220Y also matches the pinout of the 2716 EPROM or the 2816 EEPROM, allowing direct substitution while enhancing performance. There is no limit on the number of write cycles that can be executed and no additional support circuitry is required for micro-processor interfacing.

READ MODE

The DS1220Y executes a read cycle whenever \overline{WE} (Write Enable) is inactive (high) and \overline{CE} (Chip Enable) and \overline{OE} (Output Enable) are active (low). The unique address specified by the 11 address inputs (A0–A10) defines which of the 2048 bytes of data is to be accessed. Valid data will be available to the eight data output drivers within t_{ACC} (Access Time) after the last address input signal is stable, providing that \overline{CE} and \overline{OE} access times are also satisfied. If \overline{CE} and \overline{OE} access times are not satisfied, then data access must be measured from the later occurring signal and the limiting parameter is either t_{CO} for \overline{CE} or t_{OE} for \overline{OE} rather than address access.

WRITE MODE

The DS1220Y executes a write cycle whenever the \overline{WE} and \overline{CE} signals are active (low) after address inputs are stable. The latter occurring falling edge of \overline{CE} or \overline{WE} will determine the start of the write cycle. The write cycle is terminated by the earlier rising edge of \overline{CE} or \overline{WE} . All address inputs must be kept valid throughout the write cycle. \overline{WE} must return to the high state for a minimum

recovery time (t_{WR}) before another cycle can be initiated. The \overline{OE} control signal should be kept inactive (high) during write cycles to avoid bus contention. However, if the output drivers are enabled (\overline{CE} and \overline{OE} active) then \overline{WE} will disable the outputs in t_{ODW} from its falling edge.

DATA RETENTION MODE

The DS1220Y provides full functional capability for V_{CC} greater than 4.5 volts and write protects at 4.25 nominal. Data is maintained in the absence of V_{CC} without any additional support circuitry. The DS1220Y constantly monitors V_{CC} . Should the supply voltage decay, the NV SRAM automatically write protects itself, all inputs become “don’t care,” and all outputs become high impedance. As V_{CC} falls below approximately 3.0 volts, a power switching circuit connects the lithium energy source to RAM to retain data. During power-up, when V_{CC} rises above approximately 3.0 volts, the power switching circuit connects external V_{CC} to RAM and disconnects the lithium energy source. Normal RAM operation can resume after V_{CC} exceeds 4.5 volts.

ABSOLUTE MAXIMUM RATINGS*

Voltage on Any Pin Relative to Ground
 Operating Temperature
 Storage Temperature
 Soldering Temperature

−0.3V to +7.0V
 0°C to 70°C; −40°C to +85°C for IND parts
 −40°C to +70°C; −40°C to +85°C for IND parts
 260°C for 10 seconds

* This is a stress rating only and functional operation of the device at these or any other conditions above those indicated in the operation sections of this specification is not implied. Exposure to absolute maximum rating conditions for extended periods of time may affect reliability.

RECOMMENDED DC OPERATING CONDITIONS(t_A: See Note 10)

PARAMETER	SYMBOL	MIN	TYP	MAX	UNITS	NOTES
Power Supply Voltage	V _{CC}	4.5	5.0	5.5	V	
Input Logic 1	V _{IH}	2.2		V _{CC}	V	
Input Logic 0	V _{IL}	0.0		+0.8	V	

DC ELECTRICAL CHARACTERISTICS(t_A: See Note 10; V_{CC} = 5V ± 10%)

PARAMETER	SYMBOL	MIN	TYP	MAX	UNITS	NOTES
Input Leakage Current	I _{IL}	−1.0		+1.0	μA	
I/O Leakage Current CE ≥ V _{IH} ≤ V _{CC}	I _{IO}	−1.0		+1.0	μA	
Output Current @ 2.4V	I _{OH}	−1.0			mA	
Output Current @ 0.4V	I _{OL}	2.0			mA	
Standby Current CE = 2.2V	I _{CCS1}		3.0	7.0	mA	
Standby Current CE = V _{CC} −0.5V	I _{CCS2}		2.0	4.0	mA	
Operating Current t _{CYC} =200 ns (Commercial)	I _{CCO1}			75	mA	
Operating Current t _{CYC} =200 ns (Industrial)	I _{CCO1}			85	mA	
Write Protection Voltage	V _{TP}		4.25		V	

CAPACITANCE(t_A = 25°C)

PARAMETER	SYMBOL	MIN	TYP	MAX	UNITS	NOTES
Input Capacitance	C _{IN}		5	10	pF	
Input/Output Capacitance	C _{I/O}		5	12	pF	

AC ELECTRICAL CHARACTERISTICS(t_A: See Note 10; V_{CC}=5.0V ± 10%)

PARAMETER	SYM	DS1220Y-100		DS1220Y-120		DS1220Y-150		DS1220Y-200		UNITS	NOTE
		MIN	MAX	MIN	MAX	MIN	MAX	MIN	MAX		
Read Cycle Time	t _{RC}	100		120		150		200		ns	
Access Time	t _{ACC}		100		120		150		200	ns	
$\overline{\text{OE}}$ to Output Valid	t _{OE}		50		60		70		100	ns	
$\overline{\text{CE}}$ to Output Valid	t _{CO}		100		120		150		200	ns	
$\overline{\text{OE}}$ or $\overline{\text{CE}}$ to Output Active	t _{COE}	5		5		5		5		ns	5
Output High Z from Deselection	t _{OD}		35		35		35		35	ns	5
Output Hold from Address Change	t _{OH}	5		5		5		5		ns	
Write Cycle Time	t _{WC}	100		120		150		200		ns	
Write Pulse Width	t _{WP}	75		90		100		150		ns	3
Address Setup Time	t _{AW}	0		0		0		0		ns	
Write Recovery Time	t _{WR1}	0		0		0		0		ns	12
	t _{WR2}	10		10		10		10		ns	13
Output High Z from $\overline{\text{WE}}$	t _{ODW}		35		35		35		35	ns	5
Output Active from $\overline{\text{WE}}$	t _{OEW}	5		5		5		5		ns	5
Data Setup Time	t _{DS}	40		50		60		80		ns	4
Data Hold Time	t _{DH1}	0		0		0		0		ns	12
	t _{DH2}	10		10		10		10		ns	13

READ CYCLE

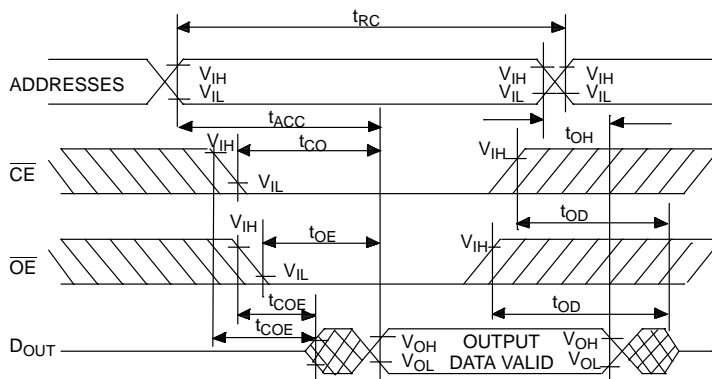

SEE NOTE 1

WRITE CYCLE 1

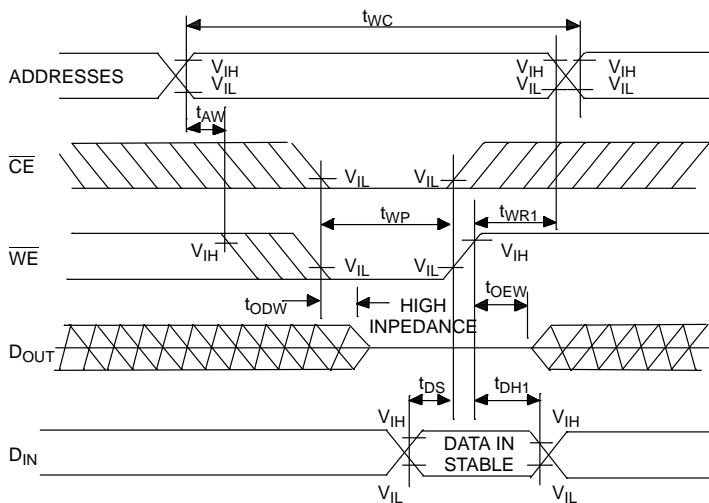

SEE NOTES 2, 3, 4, 6, 7, 8 AND 12

WRITE CYCLE 2

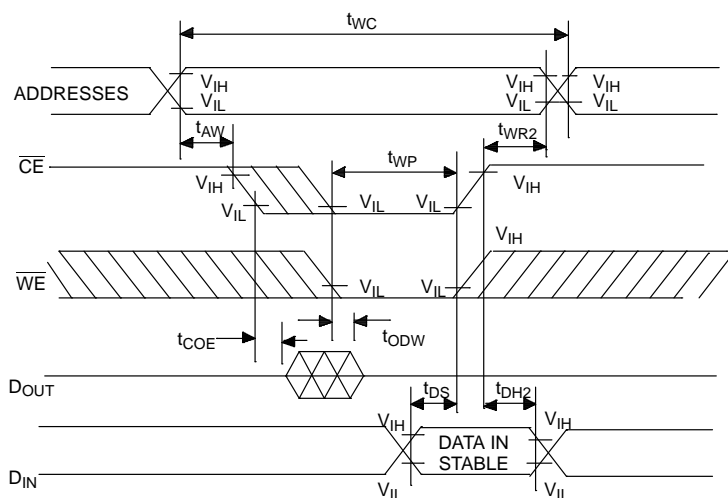

SEE NOTES 2, 3, 4, 6, 7, 8 AND 13

POWER-DOWN/POWER-UP CONDITION

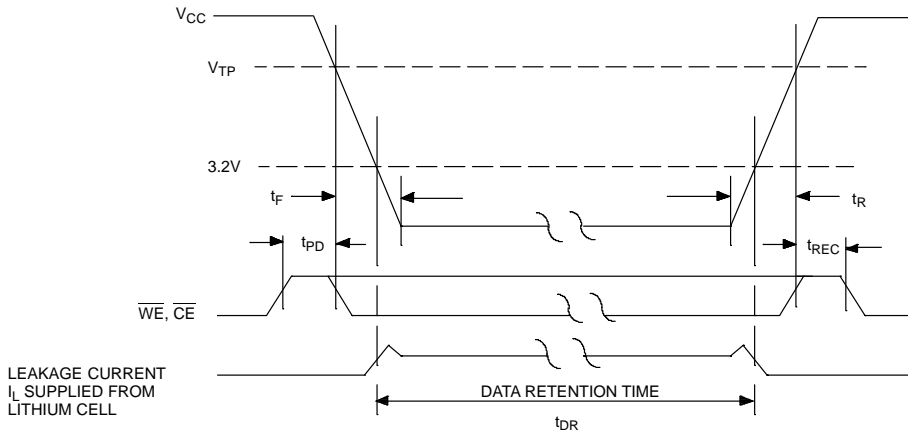

SEE NOTE 11

POWER-DOWN/POWER-UP TIMING

PARAMETER	SYMBOL	MIN	MAX	UNITS	NOTES
\overline{CE} at V_{IH} before Power-Down	t_{PD}	0		μs	11
V_{CC} Slew from V_{TP} to 0V	t_F	100		μs	
V_{CC} Slew from 0V to V_{TP}	t_R	0		μs	
\overline{CE} at V_{IH} after Power-Up	t_{REC}		2	ms	

 $(t_A = 25^\circ\text{C})$

PARAMETER	SYMBOL	MIN	MAX	UNITS	NOTES
Expected Data Retention Time	t_{DR}	10		years	9

WARNING:

Under no circumstance are negative undershoots, of any amplitude, allowed when device is in battery backup mode.

NOTES:

- \overline{WE} is high for a read cycle.
- $\overline{OE} = V_{IH}$ or V_{IL} . If $\overline{OE} = V_{IH}$ during a write cycle, the output buffers remain in a high impedance state.
- t_{WP} is specified as the logical AND of \overline{CE} and \overline{WE} . t_{WP} is measured from the latter of \overline{CE} or \overline{WE} going low to the earlier of \overline{CE} or \overline{WE} going high.
- t_{DS} are measured from the earlier of \overline{CE} or \overline{WE} going high.
- These parameters are sampled with a 5 pF load and are not 100% tested.
- If the \overline{CE} low transition occurs simultaneously with or later than the \overline{WE} low transition in write cycle 1, the output buffers remain in a high impedance state during this period.

7. If the \overline{CE} high transition occurs prior to or simultaneously with the \overline{WE} high transition, the output buffers remain in a high impedance state during this period.
8. If \overline{WE} is low or the \overline{WE} low transition occurs prior to or simultaneously with the \overline{CE} low transition, the output buffers remain in a high impedance state during this period.
9. Each DS1220Y is marked with a 4-digit date code AABB. AA designates the year of manufacture. BB designates the week of manufacture. The expected t_{DR} is defined as starting at the date of manufacture.
10. All AC and DC electrical characteristics are valid over the full operating temperature range. For commercial products, this range is 0°C to 70°C. For industrial products (IND), this range is -40°C to +85°C.
11. In a power down condition the voltage on any pin may not exceed the voltage of V_{CC} .
12. t_{WR1} , t_{DH1} are measured from \overline{WE} going high.
13. t_{WR2} , t_{DH2} are measured from \overline{CE} going high.
14. DS1220Y modules are recognized by Underwriters Laboratory (U.L.®) under file E99151 (R).

DC TEST CONDITIONS

Outputs open.

All voltages are referenced to ground.

AC TEST CONDITIONS

Output Load: 100pF + 1TTL Gate

Input Pulse Levels: 0–3.0V

Timing Measurement Reference Levels

Input: 1.5V

Output: 1.5V

Input Pulse Rise and Fall Times: 5ns

ORDERING INFORMATION

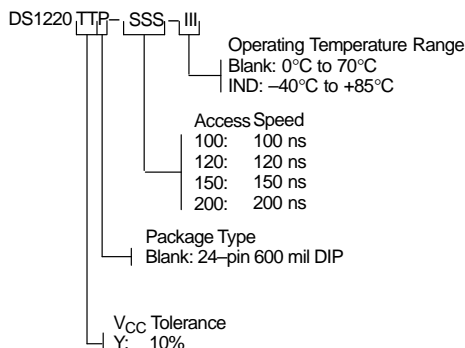

DS1220Y NONVOLATILE SRAM, 24-PIN 720 MIL EXTENDED MODULE

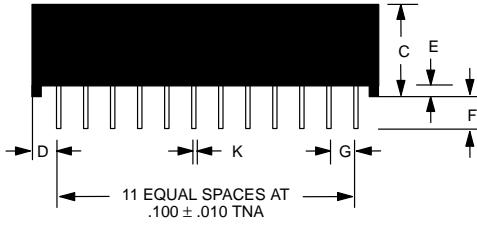
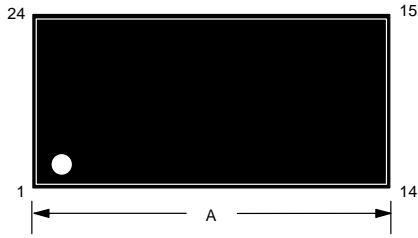

PKG	24-PIN	
	DIM	MIN
A IN.	1.320	1.340
MM	33.53	34.04
B IN.	0.695	0.720
MM	17.65	18.29
C IN.	0.390	0.415
MM	9.91	10.54
D IN.	0.100	0.130
MM	2.54	3.30
E IN.	0.017	0.030
MM	0.43	0.76
F IN.	0.120	0.160
MM	3.05	4.06
G IN.	0.090	0.110
MM	2.29	2.79
H IN.	0.590	0.630
MM	14.99	16.00
J IN.	0.008	0.012
MM	0.20	0.30
K IN.	0.015	0.021
MM	0.38	0.53

