

VIA

User's Manual

VIA EPIA

Mini-ITX Mainboard

Version 1.0
March 21, 2002

P/N 99-51-010061

Copyright

Copyright by VIA Technologies Inc. (“VIA”). No part of this manual may be reproduced or transmitted in any form without express written authorization from VIA.

Trademarks

All trademarks are the property of their respective holders.

Data protection

All data should be backed-up prior to the installation of any drive unit or storage peripheral. VIA will not be responsible for any loss of data resulting from the use, disuse or misuse of this or any other VIA product.

No Warranty

VIA has made every effort to ensure the accuracy of the content of this manual. However, it is possible that it may contain technical inaccuracies or typographical or other errors. VIA will assume no liability for any inaccuracy found in this publication, nor for damages, direct, indirect, incidental, consequential or otherwise, that may result from such an inaccuracy, including without limitation loss of data or profits.

VIA provides this manual “as is”, and does not issue a warranty of any kind, express or implied, including without limitation implied warranties of merchantability or fitness for a particular purpose.

The information provided in this manual is subject to change without notice. VIA reserves the right to alter product designs, layouts or drivers without notification.



FCC-B Radio Frequency Interference Statement

This equipment has been tested and found to comply with the limits for a class B digital device, pursuant to part 15 of the FCC rules. These limits are designed to provide reasonable protection against harmful interference when the equipment is operated in a commercial environment. This equipment generates, uses and can radiate radio frequency energy and, if not installed and used in accordance with the instruction manual, may cause harmful interference to radio communications. Operation of this equipment in a residential area is likely to cause harmful interference, in which case the user will be required to correct the interference at his own expense.

Notice 1

The changes or modifications not expressly approved by the party responsible for compliance could void the user's authority to operate the equipment.

Notice 2

Shielded interface cables and A.C. power cord, if any, must be used in order to comply with the emission limits.

VOIR LA NOTICE D'INSTALLATION AVANT DE RACCORDER AU RESEAU.

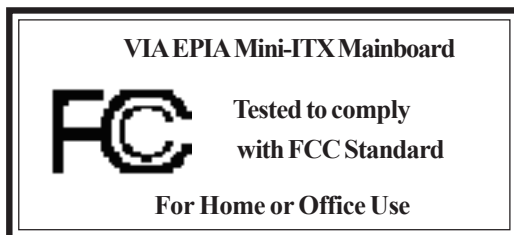

Safety Instructions

NOTE

1. Always read the safety instructions carefully.
2. Keep this User's Manual for future reference.
3. Keep this equipment away from humidity.
4. Lay this equipment on a reliable flat surface before setting it up.
5. The openings on the enclosure are for air convection hence protects the equipment from overheating. **DO NOT COVER THE OPENINGS.**
6. Make sure the voltage of the power source and adjust properly 110/220V before connecting the equipment to the power inlet.
7. Place the power cord in such a way that people cannot step on it. Do not place anything over the power cord.
8. Always unplug the power cord before inserting any add-on card or module.
9. All cautions and warnings on the equipment should be noted.
10. Never pour any liquid into the opening. Liquid can cause damage or electrical shock.
11. If any of the following situations arises, get the equipment checked by a service personnel:
 - The power cord or plug is damaged
 - Liquid has penetrated into the equipment
 - The equipment has been exposed to moisture
 - The equipment has not work well or you can not get it work according to User's Manual.
 - The equipment has dropped and damaged
 - If the equipment has obvious sign of breakage
12. **DO NOT LEAVE THIS EQUIPMENT IN AN ENVIRONMENT UNCONDITIONED, STORAGE TEMPERATURE ABOVE 60°C (140°F), IT MAY DAMAGE THE EQUIPMENT.**

CAUTION: Explosion or serious damage may occur if the battery is incorrectly replaced. Replace only with the same or equivalent type recommended by the manufacturer.

Box Contents

This VIA EPIA Mini-ITX Mainboard package should contain the following items:

- 1 x VIA EPIA Mini-ITX Mainboard
- 1 x User's manual
- 1 x ATA-33/66/100 Hard drive ribbon cables
- 1 x Driver Utilities CD
- 1 x I/O Bracket

Contents

1. Specifications	1-1
Specifications	1-2
Layout	1-4
Connectors Guide	1-5
2. Installation	2-1
CPU	2-2
Memory Installation	2-4
Power Supply	2-6
Back Panel	2-7
Connectors	2-9
Jumpers	2-14
Slots	2-18
PCI Interrupt Request Routing	2-19
3. BIOS Setup	3-1
Entering Setup	3-2
Control Keys	3-2
Getting Help	3-3
The Main Menu	3-4
Standard CMOS Features	3-6
Advanced BIOS Features	3-8
Advanced Chipset Features	3-11
Integrated Peripherals	3-15
Power Management Setup	3-20
PNP/PCI Configurations	3-26
PC Health Status	3-29
Load Fail-Safe Defaults	3-30
Load Optimized Defaults	3-31
Set Supervisor/User Password	3-32
Save & Exit Setup	3-34
Exit Without Saving	3-35

4. Software Setup	4-1
VIA Apollo PLE133 Chipset Drivers	4-2
VIA PLE133 Integrated VGA Driver	4-12
VIA Audio Driver	4-14
VIA Network Driver	4-15
VIA Fast InfraRed Device Driver	4-30

1. Specifications

The ultra-compact and highly intergrated VIA EPIA Mini-ITX Mainboard is the smallest form factor mainboard specification available today, developed by VIA Technologies, Inc as part of the company's open industry-wide Total Connectivity initiative. The VIA EPIA Mini-ITX mainboard enables the creation of an exciting new generation of small, ergonomic, innovative and affordable embedded systems. Through high levels of integration, mini-ITX only occupies 66% of the size of the FlexATX mainboard form factor. The mainboard comes with an embedded VIA Processor, boasting ultra low power consumption and cool, quiet operation.

This chapter includes the following sections:

Mainboard Specifications	1-2
Mainboard Layout	1-4
Components Guide	1-5

Specifications

CPU

- Embedded VIA Processor
- Enhanced Ball Grid Array Package (EBGA)
- Internal L1 128KB and L2 64KB cache memory

Chipset

- VIA 8601A North Bridge
- VT8231 South Bridge

Graphics

- Integrated Trident Blade 3D graphics core

Audio

- VT1612A AC'97 Codec
- 3 Audio jacks: Line-in, Line-out and Mic-in

Main Memory

- 2 x PC100/133 DIMM slots.

PCI Bus IDE

- Supports up to 4 IDE devices
- Ultra DMA 33/66/100

LAN

- VIA VT6103 Ethernet PHY
- Supports Ethernet 10/100Mb

USB

- 2 USB ports
- 1 onboard USB pin header for up to 2 additional connections
- USB v1.1 and Intel Universal HCI v1.1 compatible

TV-Out

- VIA VT1621 TV-Out Controller
- Supports 640 x 480, 800 x 600 NTSC/PAL TV
- S-Video or RCA Video output

I/O Ports

- 1 PS2 Mouse connector
- 1 PS2 Keyboard connector
- 1 15-pin External Monitor connector
- 1 16C550 compliant serial port
- 1 EPP/ECP compliant parallel port
- 1 FIR port jumper pin
- 1 CIR jumper pin

Power

- Supports ATX type power supply

Layout

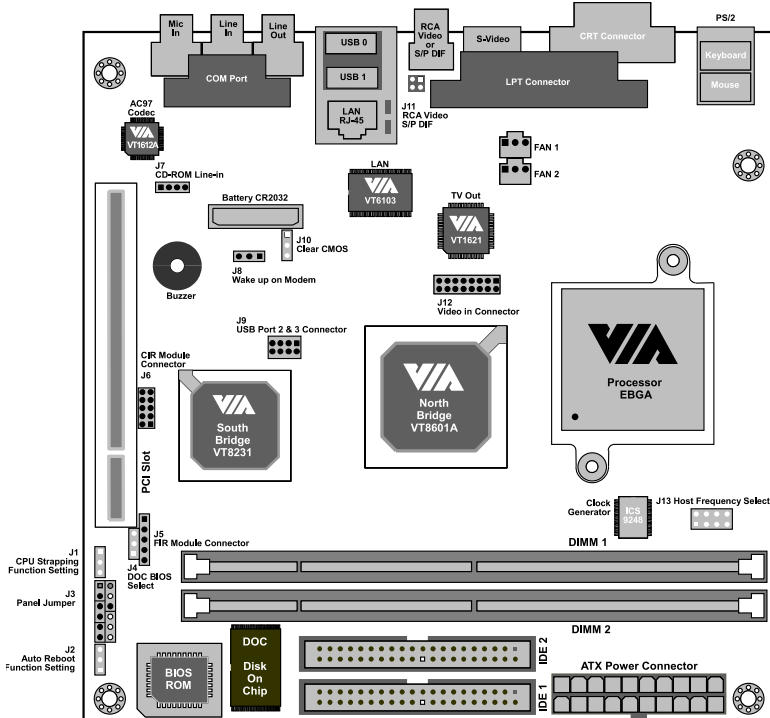

VIA EPIA Mini-ITX Mainboard
(Note: Onboard DOC is optional)

Connectors Guide

Component	Function	Reference
Fan 1, Fan 2	Fan power connectors	See p. 2-2
DIMM1, DIMM2	DIMM slot	See p. 2-4
ATX Power Connector	Connecting ATX power supply	See p. 2-6
PS/2 Mouse	Mouse connector	See p. 2-7
PS/2 Keyboard	Keyboard connector	See p. 2-7
LPT Connector	Parallel port connector	See p. 2-7
RJ-45 Port	Connecting to a LAN	See p. 2-7
COM Port	COM port connector	See p. 2-8
Line Out	Connecting Headphones/Speakers	See p. 2-8
Line In	Connecting an audio device	See p. 2-8
Mic In	Connecting a Micorphone	See p. 2-8
USB 0, USB 1	Connecting to USB devices	See p. 2-8
RCA Video or S/P DIF	Connecting to RCA Video or SPDIF	See p. 2-8
S-Video	Connecting to S-Video	See p. 2-8
CRT connector	Connect to CRT monitor	See p. 2-8
IDE 1, IDE 2	Connecting IDE devices	See p. 2-9
J3	Front panel connectors	See p. 2-10
J7	CD-ROM Line in connector	See p. 2-10
J5	FIR module connector	See p. 2-11
J6	CIR module connector	See p. 2-11
J8	Wake on Modem	See p. 2-12
J9	USB Port 2 &3 Connector	See p. 2-12
J12	Video In and PCI Riser connector	See p. 2-13
J10	Clear CMOS jumper	See p. 2-14
J13	Host Frequency Select	See p. 2-15
J2	Auto Reboot Function Setting	See p. 2-16
J1	CPU Strapping Function Setting	See p. 2-16
J4	Disk On Chip (DOC) BIOS	See p. 2-17
J11	RCA Video / S/P DIF	See p. 2-17
PCI Slot	Connecting to expansion cards	See p. 2-18

2. Installation

This chapter provides you with information about hardware setup procedures. While installing, be careful in holding the components and follow the installation procedures. Some components can be damaged if installed incorrectly. If possible, use a grounded wrist strap before handling computer components. The components can be damaged by static electricity.

This chapter contains the following topics:

Central Processing Unit (CPU)	2-2
Memory Installation	2-4
Power Supply	2-6
Back Panel	2-7
Connectors	2-9
Jumpers	2-14
Slots	2-18
PCI Interrupt Request Routing	2-19

CPU

The VIA EPIA Mini-ITX Mainboard includes an embedded VIA Eden Processor or VIA C3™ E-Series Processor. Two fan connectors (Fan 1 & Fan 2) are provided on the mainboard, allowing for the connection of a CPU fan and an additional system case fan.

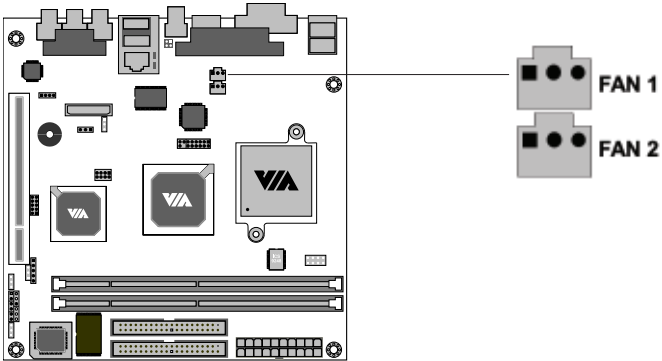

The VIA C3™ E-Series Processor

With low power consumption and advanced thermal dissipation properties, the embedded VIA C3™ E-Series requires only a small fan to guarantee performance and reliability. Ensure that the CPU Fan Connector is correctly installed, as displayed below.

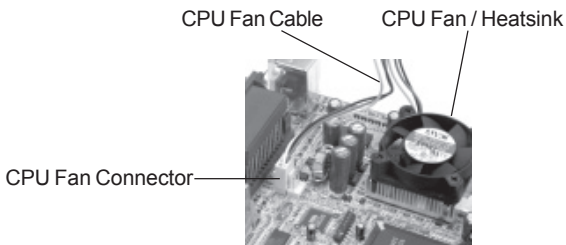

The VIA Eden Processor

Providing ultra-low power consumption and advanced thermal dissipation properties, the VIA Eden Processor features a fanless design. The VIA Eden Processor requires only a heatsink, as shown below.

CPU Heatsink

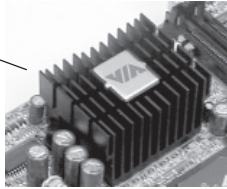

WARNING!

Overclocking

*This motherboard is not designed to support overclocking. Any attempt to operate beyond product specifications is not recommended. **We do not guarantee the damages or risks caused by operation beyond product specifications.***

Memory Installation

The VIA EPIA Mini-ITX Mainboard provides two 168-pin DIMM slots for PC 100/133 SDRAM memory modules. To operate properly, at least one module must be installed.

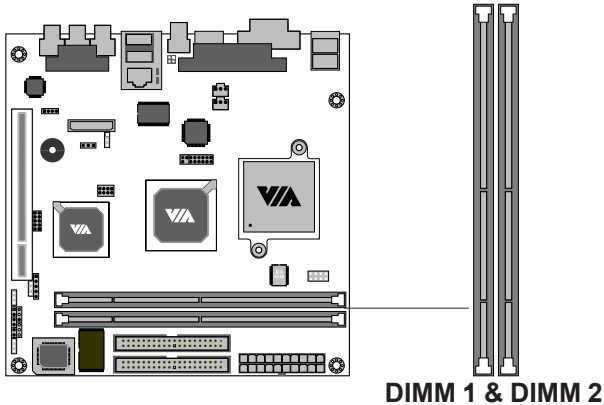

SDRAM Module Installation Procedures

- 1.) Push the white retaining latches at either end of the DIMM slot outwards.
- 2.) Align the SDRAM module with the corresponding notches on the DIMM slot. The modules will only fit if placed in the correct position.
- 2.) With both hands, press the SDRAM module down into the DIMM slot so that the white retaining latches rotate up and secure the module in place (see picture below).

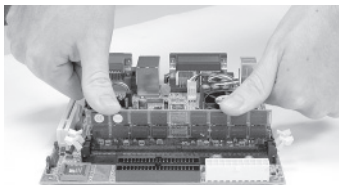

Available SDRAM Configurations

Refer to the table below for available SDRAM configurations on the VIA EPIA Mini-ITX Mainboard.

Socket	Memory Module	Total Memory
DIMM 1	32MB, 64MB, 128MB, 256MB, 512MB	32MB~512MB
DIMM 2	32MB, 64MB, 128MB, 256MB, 512MB	32MB~512MB
Maximum System Memory Supported		1GB

Power Supply

The VIA EPIA Mini-ITX Mainboard requires an ATX power supply to be connected. Before inserting the power supply connector, always make sure that all components are installed correctly to ensure that no damage will be caused.

ATX 20-Pin Power Connector

To connect the ATX power supply, make sure the plugs of the power supply are inserted in the proper orientation and the pins are correctly aligned. Then, push down the power supply plug firmly into the connector.

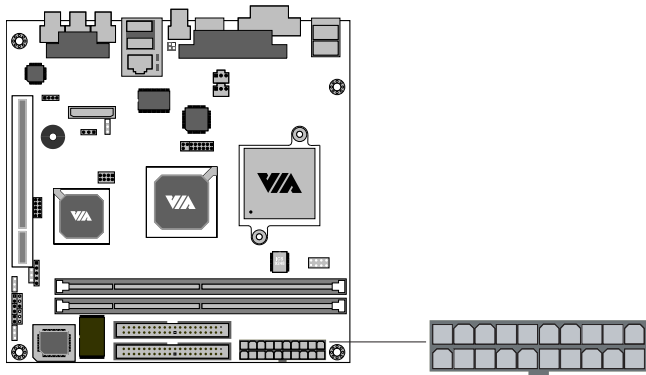

Back Panel

The back panel of the VIA EPIA Mini-ITX Mainboard contains the following connectors:

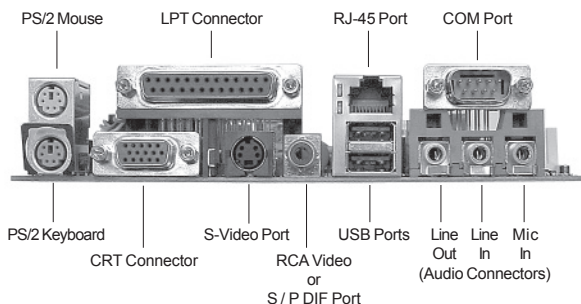

PS/2 Mouse

You can connect a PS/2 mouse directly to this standard PS/2 mouse connector.

PS/2 Keyboard

The mainboard provides a standard PS/2 keyboard connector for connecting a PS/2 keyboard.

LPT Connector

The 25-pin female parallel port for connecting printers supports Enhanced Parallel Port (EPP) and Extended Capabilities Parallel Port (ECP) modes.

RJ-45 Port

The mainboard provides a standard RJ-45 port for connection to a Local Area Network (LAN).

Chapter 2

COM Port

The mainboard provides a 9-pin male serial port connector for connecting a serial mouse or other serial devices.

Audio Connectors

Line Out is a connector for speakers or headphones. *Line In* is used for an external CD player, tape player, or other audio devices. *Mic In* is a connector for microphones.

USB Ports

The two Universal Serial Bus ports (USB 0 & USB 1) are for attaching any USB 1.1 compliant devices such as a keyboard, mouse or digital camera.

RCA Video or S/P DIF Port

This dual function port may be used either as a RCA Video port or as a S/P DIF port. An onboard jumper (J11) allows you to select what the port is used for. RCA Video provides a TV Out connection, while S/P DIF provides a 5.1 channel digital audio connection.

S-Video Port

This port supporting 640 x 480 and 800 x 600 resolutions in NTSC and PAL modes. If RCA Video function is selected, and both RCA Video/S-Video port are connected, only S-Video function will be enabled.

CRT Connector

Connect a CRT monitor to this connector for VGA display.

Connectors

The VIA EPIA Mini-ITX Mainboard provides the following connectors:

IDE Connectors

The two PCI IDE connectors (IDE 1 & IDE 2) support Ultra DMA 33/66/100 modes. IDE 1 is the primary IDE connector and IDE 2 is the secondary IDE connector. Both IDE 1 and IDE2 can connect a master and a slave drive, allowing a maximum of four separate devices, such as a HDD, CD-ROM or CD-RW, to be connected.

Also, a Disk on Module can be connected directly to one of the IDE connectors.

These connectors utilize the provided IDE cable.

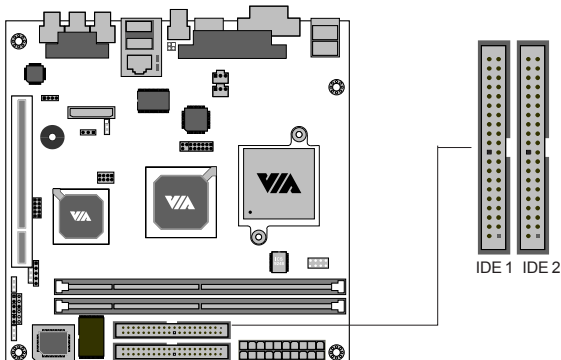

NB: If you install two HDDs on one IDE cable, you must set the second drive to *slave* mode by setting its jumper on the HDD. Please refer to the HDD documentation supplied by the HDD vendor for correct jumper setting instructions.

Chapter 2

Front Panel Connectors (J3)

The J3 front panel connectors allow you to connect the Power Switch, Reset Switch, Power LED and HDD LED to the system case.

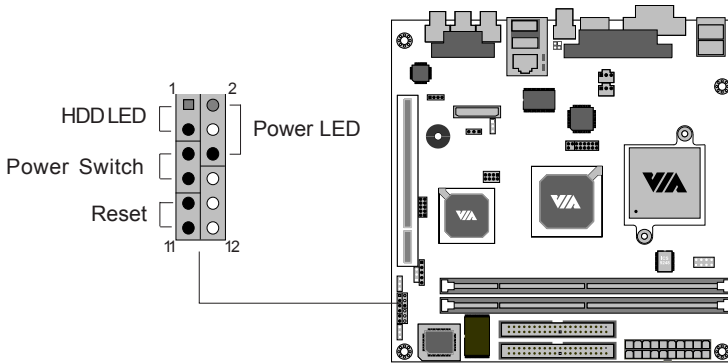

CD-ROM Line In Connector (J7)

The J7 internal CD-ROM Line In Connector allows you to connect and receive audio input from a device such as a CD-ROM.

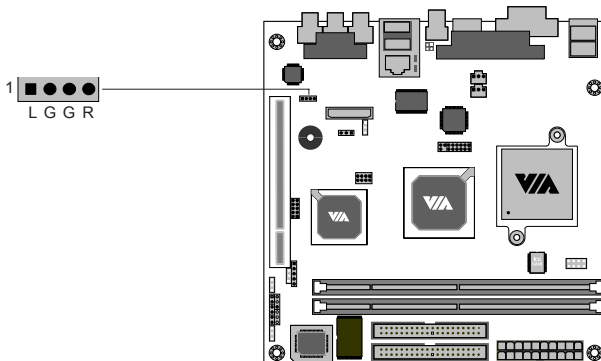

FIR Module Connector (J5)

The FIR Module Connector (J5) allows you to connect a Fast Infrared standard module. This is not for standard FIR module, for reference design please consult with VIA Technologies, Inc.

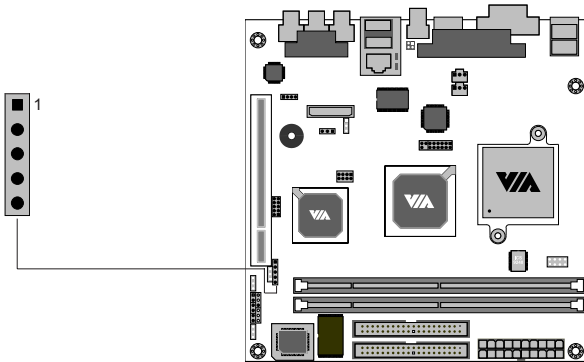

CIR Module Connector (J6)

The CIR Module Connector (J6) allows you to connect a Consumer Infrared standard module. This is not for standard CIR module, for reference design please consult with VIA Technologies, Inc.

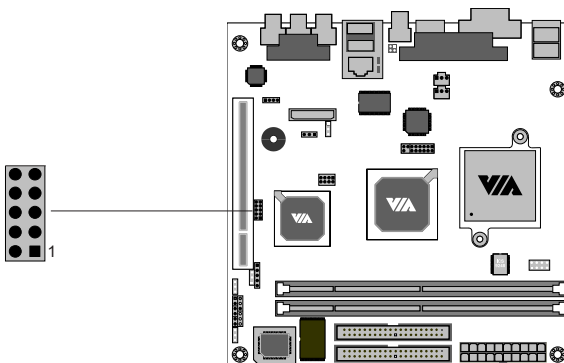

Chapter 2

Wake On Modem Connector (J8)

This connector (J8) allows you to connect to a modem with the Wake On Modem function. The connector will power up the system when a signal is received through the modem.

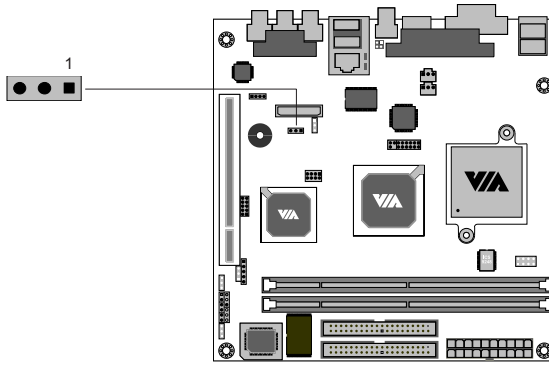

USB Port 2 & 3 Connector (J9)

This connector (J9) allows you to connect an additional two Universal Serial Bus (USB) ports, in case the two USB ports on the back panel are not sufficient. To utilize the additional two USB connections you need to connect a 2 port USB module to the J9 connector. This is not for standard USB port module, for reference design please consult with VIA Technologies, Inc.

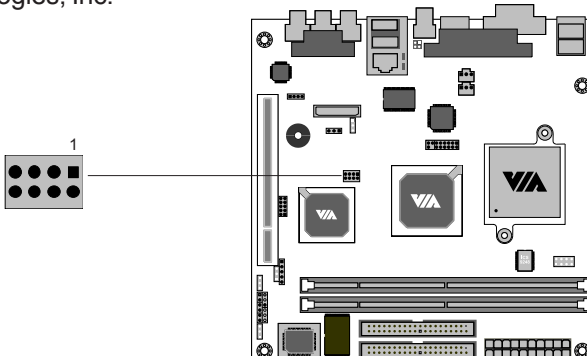

Video In Connector and PCI Riser Card Connector (J12)

The Video In Connector (right part of J12, see diagram below) allows you to connect an external video source. The PCI Riser Card Connector (left part of J12, see diagram below) allows you to connect a PCI Riser Card module. These connectors are not for standard Video In and PCI Riser Card module, for reference design please consult with VIA Technologies, Inc.

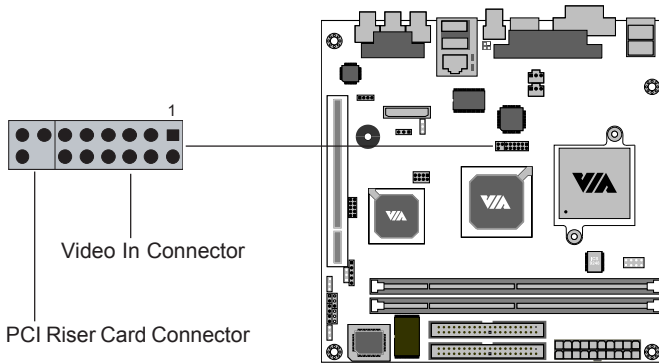

Jumpers

The VIA EPIA Mini-ITX Mainboard provides a series of jumpers to set the computer's functions. This section explains the functions of all the mainboard settings.

Clear CMOS (J10)

The Clear CMOS jumper allows you to clear the CMOS memory of system parameter settings. If you want to clear the system configuration, use the JBAT1 (Clear CMOS Jumper) to clear data. Follow the instructions below to clear the data:

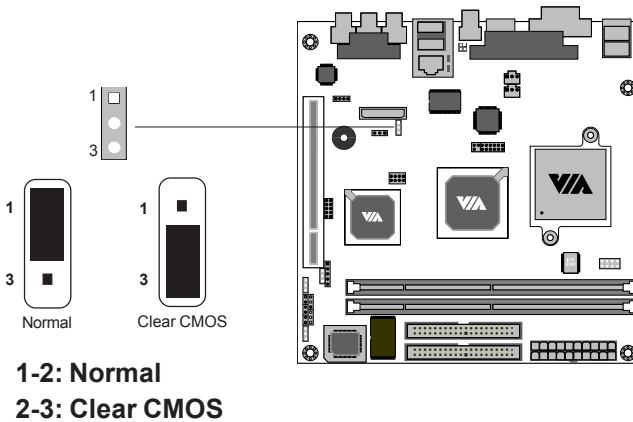

WARNING! *Do not clear the CMOS while the system is on; it may cause damage to the mainboard.*

Host Frequency Select (J13)

This jumper can be used to select the host frequency bus speed of the mainboard. The three available options are 66MHz, 100MHz and 133MHz.

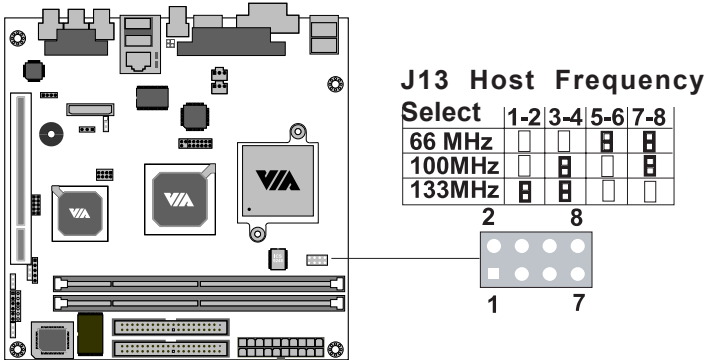

WARNING! Overclocking

This motherboard is not designed to support overclocking. Any attempt to operate beyond product specifications is not recommended. **We do not guarantee the damages or risks caused by operation beyond product specifications.**

Chapter 2

Auto Reboot Function Setting (J2)

This jumper enables or disables the Auto Reboot Function Setting. When enabled, the system will automatically reboot in the event of sudden power outage.

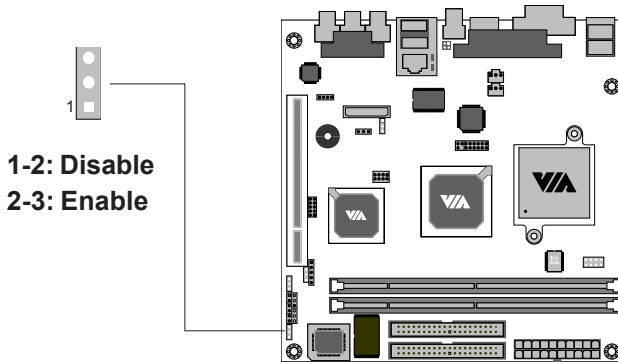

CPU Strapping Function Setting (J1)

This jumper enables or disables the CPU Strapping Function Setting.

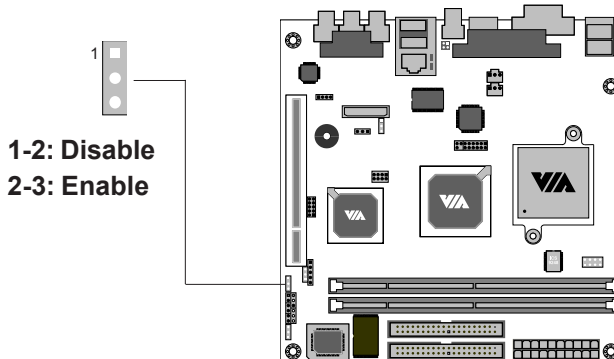

DOC BIOS Select (J4)

This jumper enables or disables the Disk on Chip (DOC) BIOS Select Function. The DOC function is not a standard option on this mainboard and is a manufacturing option only. Therefore the DOC function may not be present on the mainboard you have purchased.

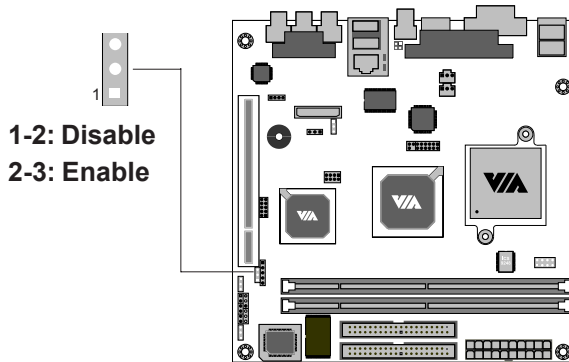

RCA Video or S/P DIF Select (J11)

This jumper selects either RCA Video or S/P DIF as the enabled function on the dual purpose port.

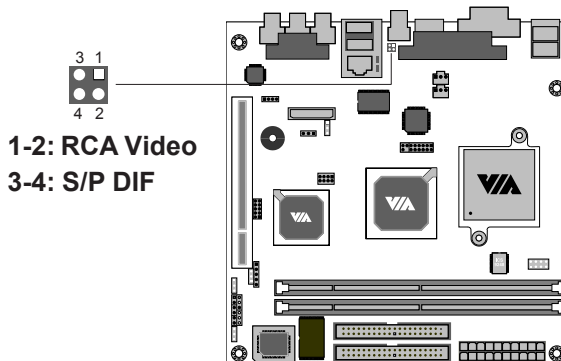

Slots

PCI Slot

The PCI slot allows you to insert PCI expansion card. When adding or removing expansion cards, make sure that you unplug the power supply first. Meanwhile, read the documentation for the expansion card to make any necessary hardware or software settings for the expansion card, such as jumpers, switches or BIOS configuration.

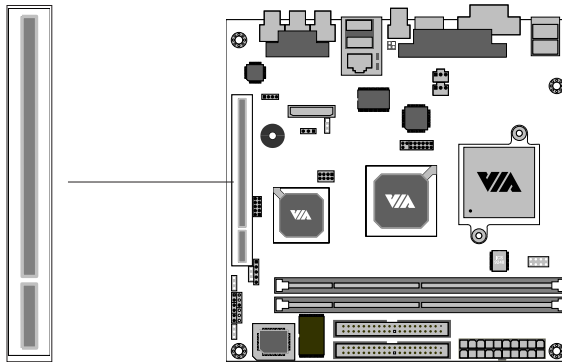

For two PCI slot solution, a PCI Riser Card module can be used. For reference design please consult with VIA Technologies, Inc.

PCI Interrupt Request Routing

The IRQ (Interrupt ReQuest) is the mechanism for devices to request services from the microprocessor. The “PCI & LAN” IRQ pins are typically connected to the PCI bus INT A# ~ INT D# pins as follows:

	Order 1	Order 2	Order 3	Order 4
PCI Slot 1	INT B#	INT C#	INT D#	INT A#
LAN	INT B#			

3. BIOS Setup

This chapter gives detailed explanation of the BIOS setup functions. It consists of the following topics:

Entering Setup	3-2
Control Keys	3-2
Getting Help	3-3
The Main Menu	3-4
Standard CMOS Features	3-6
Advanced BIOS Features	3-8
Advanced Chipset Features	3-11
Integrated Peripherals	3-15
Power Management Setup	3-20
PNP/PCI Configurations	3-26
PC Health Status	3-29
Load Fail-Safe Defaults	3-30
Load Optimized Defaults	3-31
Set Supervisor/User Password	3-32
Save & Exit Setup	3-34
Exit Without Saving	3-35

Entering Setup

Power on the computer and press DEL straight away to enter the BIOS setup menu.

If you missed the BIOS setup entry point, you may restart the system and try again.

Control Keys

<↑>	Move to the previous item
<↓>	Move to the next item
<←>	Move to the item in the left hand column
<→>	Move to the item in the right hand column
<Enter>	Select the item
<Esc>	Jumps to the Exit menu or returns to the main menu from a submenu
<+/PU>	Increase the numeric value or make changes
<-/PD>	Decrease the numeric value or make changes
<F1>	General help, only for Status Page Setup Menu and Option Page Setup Menu
<F5>	Restore the previous CMOS value from CMOS, only for Option Page Setup Menu
<F6>	Load the default CMOS value from Fail-Safe default table, only for Option Page Setup Menu
<F7>	Load Optimized defaults
<F10>	Save all the CMOS changes and exit

Getting Help

After entering the BIOS setup menu, the Main Menu appears.

Main Menu

The main menu displays all BIOS setup categories. Use the control keys (↓↑) to select any item/sub-menu. A description of the selected/highlighted category is displayed at the bottom of the screen.

Sub-Menu

If you find a right pointer symbol (as shown in the window on the right) on the left of a field, this means a sub-menu is available. The sub-menu contains additional options. You can use control keys (↓↑) to highlight the field and press <Enter> to enter the sub-menu. To return from the sub-menu press <Esc >.

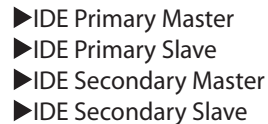

- ▶ IDE Primary Master
- ▶ IDE Primary Slave
- ▶ IDE Secondary Master
- ▶ IDE Secondary Slave

General Help <F1>

The BIOS setup program provides a General Help screen. You can call up this screen from any menu/sub-menu by pressing <F1>. The help screen displays the keys for use and navigate the BIOS setup. Press <Esc> to exit the help screen.

The Main Menu

The Main Menu contains eleven setup functions and two exit choices. Use arrow keys to select the items and press <Enter> to accept or enter the sub-menu.

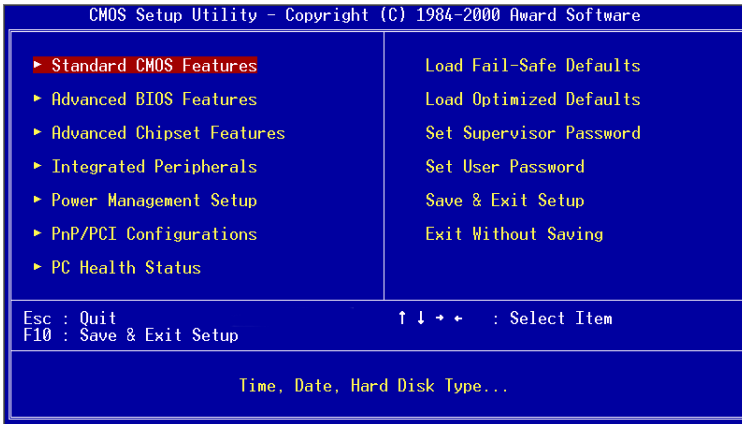

Standard CMOS Features

Use this menu to set basic system configurations.

Advanced BIOS Features

Use this menu to set the advanced features available on your system.

Advanced Chipset Features

Use this menu to set chipset specific features and optimize system performance.

Integrated Peripherals

Use this menu to set onboard peripherals features.

Power Management Setup

Use this menu to set onboard power management functions.

PnP/PCI Configurations

Use this menu to set the PnP and PCI configurations.

PC Health Status

This menu shows the PC health status.

Load Fail-Safe Defaults

Use this menu to load the BIOS default settings for minimal and stable system operations.

Load Optimized Defaults

Use this menu to load BIOS default settings for optimal and high performance system operations.

Set Supervisor Password

Use this menu to set supervisor password.

Set User Password

Use this menu to set user password.

Save & Exit Setup

Save BIOS setting changes and exit setup.

Exit Without Saving

Abandon all BIOS setting changes and exit setup.

Standard CMOS Features

Use the arrow keys to highlight the item and use the <PgUp> or <PgDn> keys to select the value you desire for each item.

```

CMOS Setup Utility - Copyright (C) 1984-2000 Award Software
Standard CMOS Features

Date (mm:dd:yy)      Wed, Mar  6 2002
Time (hh:mm:ss)     11 : 33 : 17

▶ IDE Primary Master
▶ IDE Primary Slave
▶ IDE Secondary Master
▶ IDE Secondary Slave

Video                [EGA/VGA]
Halt On              [All , But Keyboard]

Base Memory          640K
Extended Memory     65472K
Total Memory         1024K

Item Help
Menu Level ▶
Change the day, month,
year and century

↑↓←→:Move  Enter:Select  +/-/PU/PD:Value  F10:Save  ESC:Exit  F1:General Help
F5:Previous Values  F6:Fail-Safe Defaults  F7:Optimized Defaults

```

Date

The date format is <Day><Month><Date><Year>.

Day - day of the week, for example Friday. Read-only.

Month - the month from Jan to Dec.

Date - the date from 1 to 31.

Year - the year, range from 1994 to 2079.

Time

The time format is <Hour><Minute><Second>.

Video

Set the video mode. Available options are *EGA/VGA*, *CGA 40*, *CGA 80* and *Mono*.

Halt On

Determine the system behaviour if an error is detected during bootup.

Settings:

All Errors System halts when any error is detected.

No Errors System does not halt for any error.

All, But Keyboard System halts for all errors (except keyboard error).

- All, But Diskette* System halts for all errors (except diskette error).
- All, But Disk/Key* System halts for all errors (except disk/KB error)

IDE Primary Master/Slave and Secondary Master/Slave

Press <Enter> to enter the sub-menu and the following screen appears:

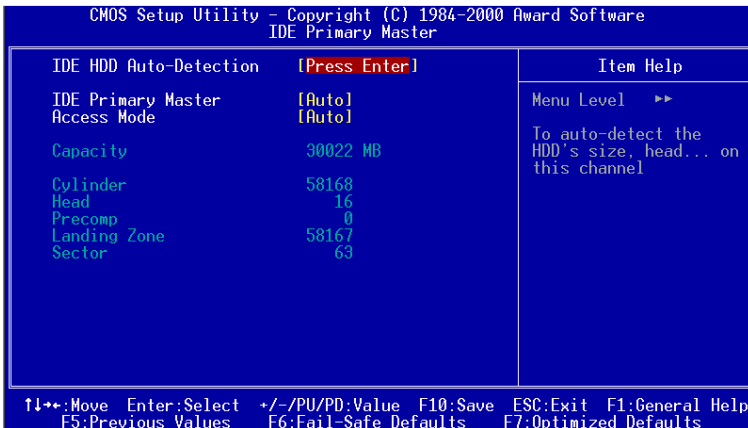

The specifications of your drive must match with the drive table. The hard disk will not work properly if you enter improper information for this category. Select Auto whenever possible. If you select Manual, make sure the information provided is from your hard disk vendor or system manufacturer.

- IDE Primary Master** The settings are None, Auto, Manual.
- Access Mode** The settings are CHS, LBA, Large, Auto.
- Capacity** The formatted size of the storage device.
- Cylinder** Number of cylinders.
- Head** Number of heads.
- Precomp** Write precompensation.
- Landing Zone** Cylinder location of the landing zone.
- Sector** Number of sectors.

Advanced BIOS Features

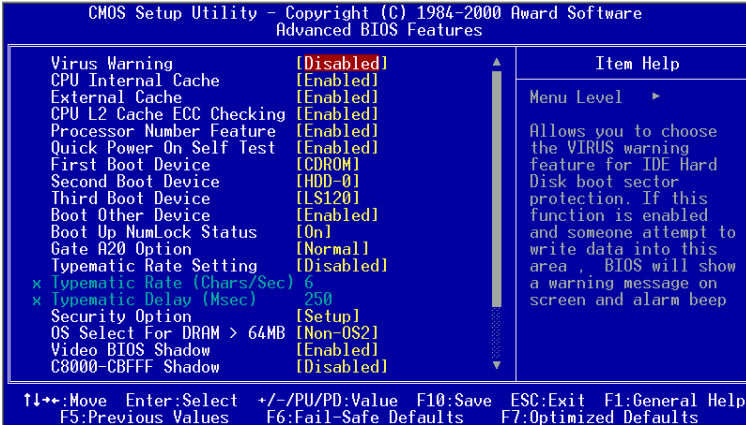

Virus Warning

Set the Virus Warning feature for IDE Hard Disk boot sector protection. If the function is enabled, any attempt to write data into this area will cause a beep and a warning message will be displayed. Settings: *Disabled* and *Enabled*.

CPU Internal Cache

Enable the CPU Internal Cache. Settings: *Enabled* and *Disabled*.

External Cache

Enable the CPU L2 Cache. Settings: *Enabled* and *Disabled*.

CPU L2 Cache ECC Checking

Set the ECC (Error-Correcting Code) feature for Level 2 cache. Facilitates error detection/correction when data passes through Level 2 cache. Settings: *Enabled* and *Disabled*.

Quick Power On Self Test

Shorten Power On Self Test (POST) cycle and enable shorter bootup time. Allow BIOS to skip some check items during POST. Settings: *Enabled* and *Disabled*.

First/Second/Third Boot Device

Set the boot device sequence as BIOS attempts to load the disk operating system. The settings are:

<i>LS120</i>	The system will boot from LS-120 drive.
<i>HDD-0</i>	The system will boot from first HDD.
<i>SCSI</i>	The system will boot from SCSI.
<i>CD-ROM</i>	The system will boot from CD-ROM.
<i>HDD-1</i>	The system will boot from second HDD.
<i>HDD-2</i>	The system will boot from third HDD.
<i>HDD-3</i>	The system will boot from fourth HDD.
<i>ZIP100</i>	The system will boot from ATAPI ZIP drive.
<i>USB-FDD</i>	The system will boot from USB floppy drive.
<i>USB-ZIP</i>	The system will boot from USB ZIP drive.
<i>USB-CDROM</i>	The system will boot from USB CD-ROM.
<i>USB-HDD</i>	The system will boot from USB HDD drive.
<i>LAN</i>	The system will boot from network drive.
<i>Disabled</i>	Disable this sequence.

Boot Other Device

Enable the system to boot from other devices if the system fails to boot from the First/Second/Third boot device. Settings: *Enabled* and *Disabled*.

Boot Up NumLock Status

Set the NumLock status when the system is powered on. "On" will turn key pad into number keys, and "Off" will turn key pad into arrow keys. Settings: *On* and *Off*.

Gate A20 Option

Set the Gate A20 option. Settings: *Normal* and *Fast*.

Typematic Rate Setting

Set the typematic rate and delay. Settings: *Enabled* and *Disabled*.

Typematic Rate (Chars/Sec)

When Typematic Rate Setting is enabled. This item allows you to set the rate (characters/second) at which the keys are accelerated. Settings: *6, 8, 10, 12, 15, 20, 24* and *30*.

Typematic Delay (Msec)

When Typematic Rate Setting is enabled. This item allows you to select the delay between when the key was first pressed and when the acceleration begins. Settings: *250, 500, 750* and *1000*.

Security Option

Specifies the type of BIOS password protection that is implemented. Settings are described below:

Option	Description
<i>Setup</i>	The password prompt appears only when end users try to run Setup.
<i>System</i>	A password prompt appears every time when the computer is powered on or when end users try to run Setup.

OS Select For DRAM > 64MB

Select the OS type used. Settings: *Non-OS2* and *OS2*.

Video BIOS Shadow

Enable shadow for the Video BIOS. Settings: *Disabled* and *Enabled*.

C8000-CBFFF Shadow

Enable shadow in the C8000-CBFFF region. Settings: *Disabled* and *Enabled*.

CC000-CFFFF Shadow

Enable shadow in the CC000-CFFFF region. Settings: *Disabled* and *Enabled*.

D0000-D3FFF Shadow

Enable shadow in the D0000-D3FFF region. Settings: *Disabled* and *Enabled*.

D4000-D7FFF Shadow

Enable shadow in the D4000-D7FFF region. Settings: *Disabled* and *Enabled*.

D8000-DBFFF Shadow

Enable shadow in the D8000-DBFFF region. Settings: *Disabled* and *Enabled*.

DC000-DFFFF Shadow

Enable shadow in the DC000-DFFFF region. Settings: *Disabled* and *Enabled*.

Advanced Chipset Features

The Advanced Chipset Features menu is used for optimizing the chipset functions.

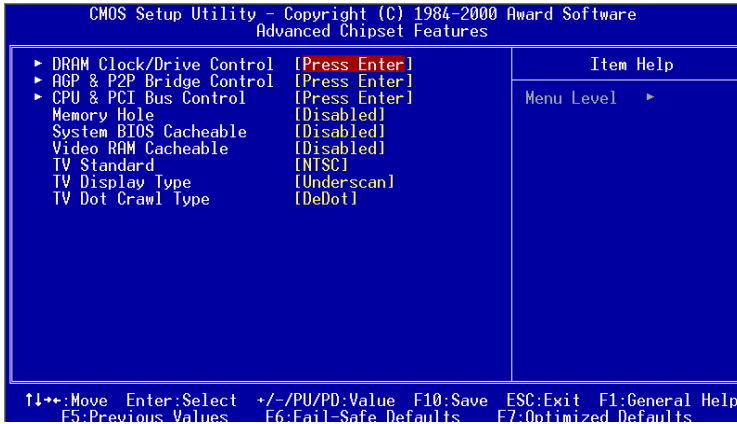

Note: Change these settings only if you are familiar with the chipset.

Memory Hole

Select whether to have a memory hole at 15M to 16M area. Settings: *Disabled* and *15M-16M*.

System BIOS Cacheable

Cache the System Bios. Settings: *Disabled* and *Enabled*.

Video RAM Cacheable

Cache the Video RAM. Settings: *Disabled* and *Enabled*.

TV Standard

Set the TV Standard of the TV output. Settings: *NTSC* and *PAL*.

TV Display Type

Set the TV Display type. Settings: *Underscan* and *Overscan*.

TV Dot Crawl Type

Set the TV Dot Crawl Type. Settings: *DeDot* and *Dot*.

DRAM Clock/Drive Control

Press <Enter> to enter the sub-menu and the following screen appears:

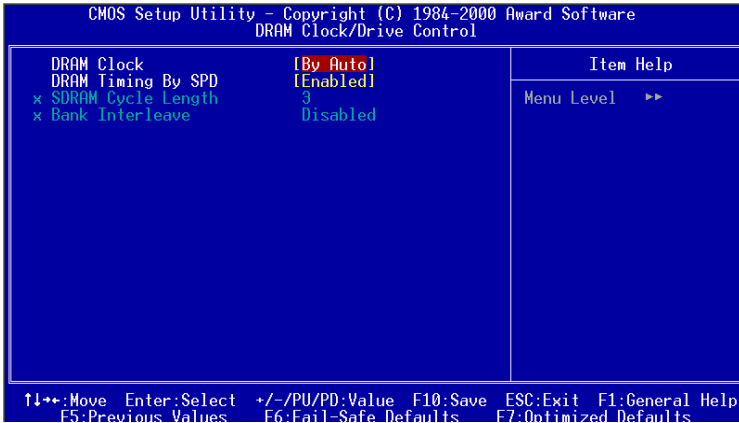

DRAM Clock

Set the DRAM Clock. Settings: *Host CLK*, *HCLK-33M* and *By Auto*.

DRAM Timing By SPD

Set DRAM Timing by SPD. Settings: *Disabled* and *Enabled*.

SDRAM Cycle Length

Set the SDRAM Cycle Length. Settings: 3 and 2.

Bank Interleave

Set the Bank Interleave mode. Settings: *Disabled*, *2 Bank* and *4 Bank*.

AGP & P2P Bridge Control

Press <Enter> to enter the sub-menu and the following screen appears:

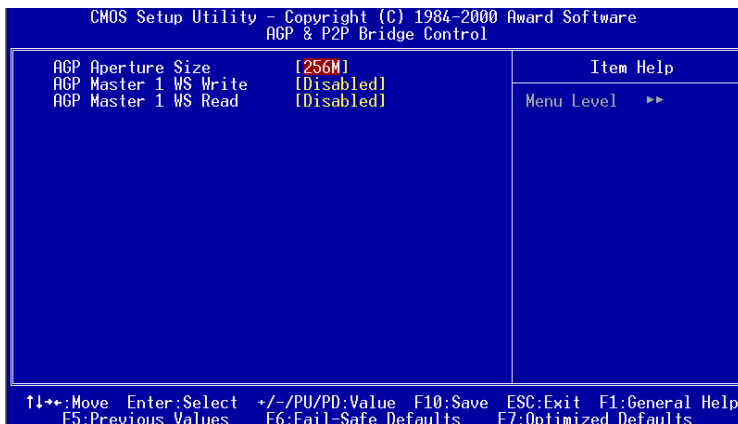

AGP Aperture Size

Set the AGP Aperture Size. Settings: 256M, 128M, 64M, 32M, 16M, 8M and 4M.

AGP Master 1 WS Write

Set the AGP Master 1 WS Write. Settings: *Disabled* and *Enabled*.

AGP Master 1 WS Read

Set the AGP Master 1 WS Read. Settings: *Disabled* and *Enabled*.

CPU & PCI Bus Control

Press <Enter> to enter the sub-menu and the following screen appears:

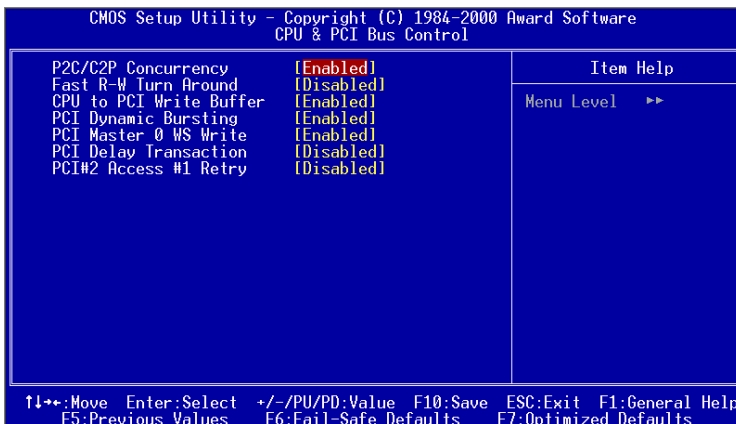

P2C/C2P Concurrency

Set the P2C/C2P Concurrency. Settings: *Disabled* and *Enabled*.

Fast R-W Turn Around

Set the Fast R-W Turn Around. Settings: *Disabled* and *Enabled*.

CPU to PCI Write Buffer

Set the CPU to PCI Write Buffer. Settings: *Disabled* and *Enabled*.

PCI Dynamic Bursting

Set the PCI Dynamic Bursting. Settings: *Disabled* and *Enabled*.

PCI Master 0 WS Write

Set the PCI Master 0 WS Write. Settings: *Disabled* and *Enabled*.

PCI Delay Transaction

Set the PCI Delay Transaction. Settings: *Disabled* and *Enabled*.

PCI #2 Access #1 Retry

Set the PCI#2 Access#1 Retry. Settings: *Disabled* and *Enabled*.

Integrated Peripherals

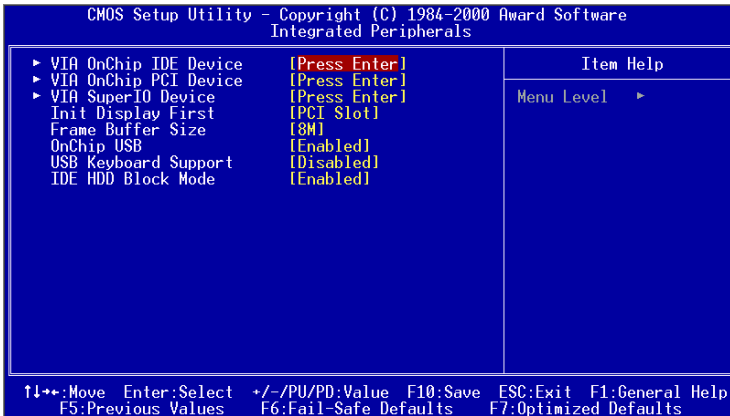

Init Display First

This setting specifies which VGA card is your primary graphics adapter. Settings: *PCI Slot* and *AGP*.

Frame Buffer Size

This setting specifies the frame buffer size. Settings: *2M*, *4M* and *8M*.

OnChip USB

Set the state of the OnChip USB. Settings: *Enabled* and *Disabled*.

USB Keyboard Support

This setting specifies whether it is necessary for BIOS to provide support for USB Keyboard. Settings: *Disabled* and *Enabled*.

IDE HDD Block Mode

This setting specifies if the IDE hard drive supports block mode. Settings: *Disabled* and *Enabled*.

VIA OnChip IDE Device

Press <Enter> to enter the sub-menu and the following screen appears:

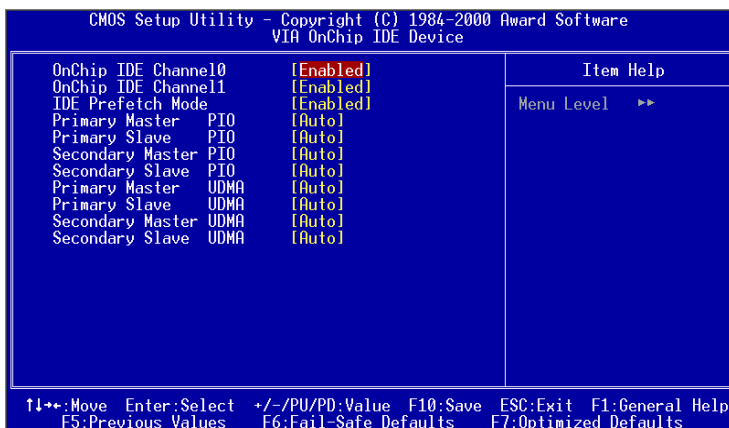

OnChip IDE Channel 0/1

The integrated peripheral controller contains an IDE interface with support for two IDE channels. Choose *Enabled* to activate each channel separately. Settings: *Disabled* and *Enabled*.

IDE Prefetch Mode

This allows your hard disk controller to use the fast block mode to transfer data to and from the hard disk drive. Block mode is also called block transfer, multiple commands or multiple sector read/write. *Enabled* enables IDE controller to use block mode; *Disabled* allows the controller to use standard mode.

Primary Master/Slave PIO

These settings specifies the PIO mode for Primary Master/Slave IDE devices. Settings: *Auto*, *Mode 0*, *Mode 1*, *Mode 2*, *Mode 3* and *Mode 4*.

Secondary Master/Slave PIO

These settings specifies the PIO mode for Secondary Master/Slave IDE devices. Settings: *Auto*, *Mode 0*, *Mode 1*, *Mode 2*, *Mode 3* and *Mode 4*.

Primary Master/Slave UDMA

These settings specifies the UDMA mode for Primary Master/Slave IDE devices. Settings: *Disabled* and *Auto*.

Secondary Master/Slave UDMA

These settings specifies the UDMA mode for Secondary Master/Slave IDE devices. Settings: *Disabled* and *Auto*.

VIA OnChip PCI Device

Press <Enter> to enter the sub-menu and the following screen appears:

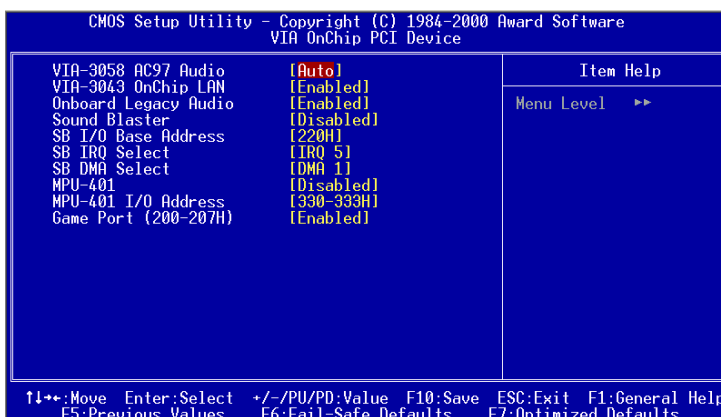

VIA-3058 AC97 Audio

Set the VIA-3058 AC97 Audio codec. Auto - automatically detect the presence of audio codec. Disabled - disable onboard audio codec. Settings: *Disabled* and *Auto*.

VIA-3043 OnChip LAN

Set the VIA -3043 OnChip LAN. Settings: *Disabled* and *Enabled*.

Onboard Legacy Audio

Set the onboard legacy audio. Settings: *Disabled* and *Enabled*.

Sound Blaster

Set the Sound Blaster option. Settings: *Disabled* and *Enabled*.

SB I/O Base Address

Set Sound Blaster I/O base address. Settings: 220H, 240H, 260H and 280H.

SB IRQ Select

Select the Sound Blaster IRQ. Settings: IRQ5, IRQ7, IRQ9 and IRQ10.

SB DMA Select

Select the Sound Blaster DMA channel. Settings: DMA 0, DMA 1, DMA 2 and DMA 3.

MPU-401

Set the MPU-401 option. Settings: Disabled and Enabled.

MPU-401 I/O Address

Set the MPU-401 I/O Address. Settings: 300-303H, 310-313H, 320-323H and 330-333H.

Game Port (200-207H)

Set the game port at address (200-207H). Settings: Disabled and Enabled.

VIA SuperIO Device

Press <Enter> to enter the sub-menu and the following screen appears:

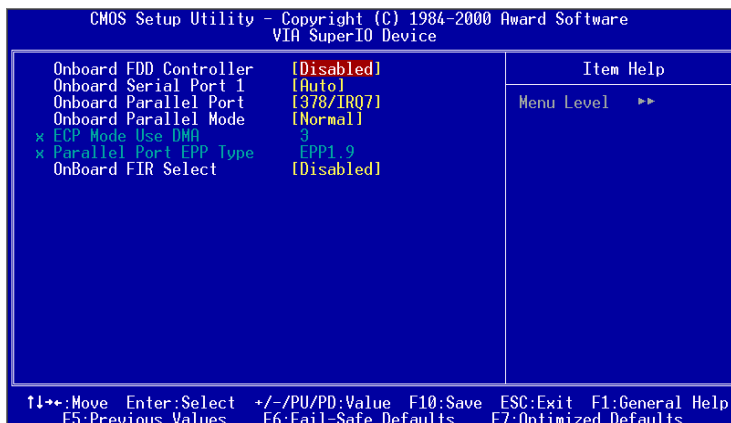

Onboard FDD Controller

Enable the onboard floppy controller. Select “Enabled” when you have installed a floppy disk drive. Settings: *Enabled* and *Disabled*.

Onboard Serial Port 1

Set the base I/O port address and IRQ for the onboard serial port 1. Selecting *Auto* allows BIOS to automatically determine the correct base I/O port address. Settings: *Disabled*, *3F8/IRQ4*, *2F8/IRQ3*, *3E8/IRQ4*, *2E8/IRQ3* and *Auto*.

Onboard Parallel Port

This specifies the I/O port address and IRQ of the onboard parallel port. Settings: *Disabled*, *3BC/IRQ7*, *378/IRQ7* and *278/IRQ5*.

Onboard Parallel Mode

Set the parallel port mode. To operate the onboard parallel port as Standard Parallel Port, choose “Normal.” To operate the onboard parallel port in the EPP mode, choose “EPP.” By choosing “ECP”, the onboard parallel port will operate in ECP mode. Choosing “ECP + EPP” will allow the onboard parallel port to support both the ECP and EPP modes simultaneously. Settings are:

Normal : Standard Parallel Port
EPP : Enhanced Parallel Port
ECP : Extended Capability Port
ECP/EPP : Extended Capability Port + Enhanced Parallel Port

ECP Mode Use DMA

ECP utilizes a DMA channel. This field is only available if Parallel Port Mode is set to “ECP”. Select DMA channel for ECP use. Settings: *1* and *3*.

Parallel Port EPP Type

Set the parallel port EPP type. This field is only available if Parallel Mode is set to “EPP”. Settings: *EPP1.9* and *EPP1.7*.

Onboard FIR Select

Select the state of the onboard FIR. Settings: *Disabled* and *Enabled*.

Power Management Setup

The Power Management Setup menu configures the system to most effectively save energy while operating in a manner consistent with your own style of computer use.

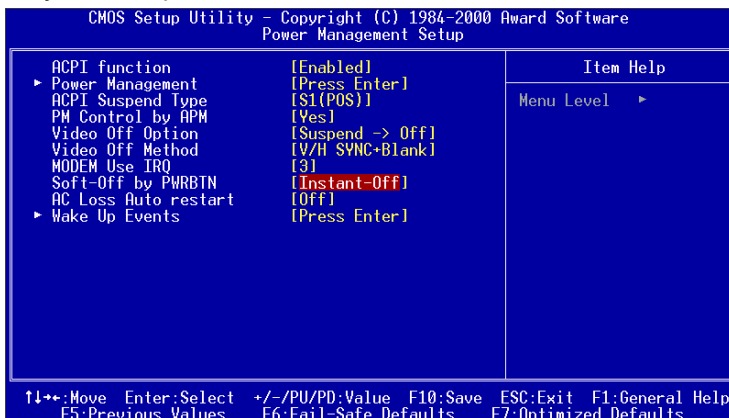

ACPI Function

Activate the ACPI (Advanced Configuration and Power Management Interface) Function. If your operating system is ACPI-aware (i.e. Windows 98/98SE/ME/2000/XP) select Enabled. Settings: *Enabled* and *Disabled*.

ACPI Suspend Type

Set the power saving mode for ACPI function. Settings are:
S1/POS - S1/Power On Suspend (POS) is a low power state. In this state, no system context (CPU or chipset) is lost and hardware maintains all system context.

S3/STR - S3/Suspend To RAM (STR) is a power-down state. In this state, power is supplied only to essential components such as main memory and wakeup-capable devices. The system context is saved to main memory, and context is restored from the memory when a "wakeup" event occurs.

PM Control by APM

Specify whether the Power Management function is controlled by APM. Settings: *No* and *Yes*.

Video Off Option

Select whether or not to turn off the screen when system enters power saving mode, ACPI OS such as Windows XP will override this option. Settings are:

Always On - The screen is always on even when system enters power saving mode.

Suspend -> Off - The screen is turned off when system enters power saving mode.

Video Off Method

Select the method of turning video off. Settings: *Blank Screen, V/H SYNC + Blank* and *DPMS Support*.

Modem Use IRQ

Select the IRQ use by modem. Settings: *NA, 3, 4, 5, 7, 9, 10* and *11*.

Soft-Off by PWRBTN

This field configures the power button function. Settings are:

Instant-Off - The power button functions as a normal power-on/-off button.

Delay 4 Sec - The system is turned off if power button is pressed for more than four seconds.

AC Loss Auto restart

Determines the power state of the system when resume from AC power loss. If enabled, the system will automatically power on when AC power is back. Settings: *Enabled* and *Disabled*.

Power Management

Press <Enter> to enter the sub-menu and the following screen appears:

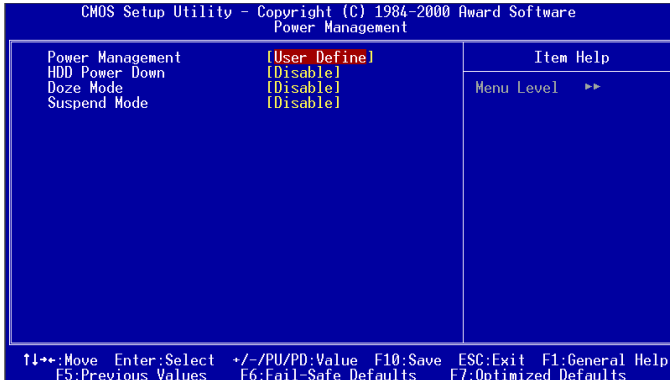

Power Management

Set the power management function to preset options or user define parameters. Min Saving - minimal power saving, provide the optimal performance. Max Saving - minimal power consumption. Settings: *User Define*, *Min Saving* and *Max Saving*.

HDD Power Down

The HDD power down timer. Settings: *Disable*, *1 ~ 15Min*.

Doze Mode

Set the doze mode. Only available if Power Management function is set to User Define. Settings: *Disable*, *1 Min*, *2 Min*, *4 Min*, *6Min*, *8Min*, *10 Min*, *20 Min*, *30 Min*, *40Min* and *1Hour*.

Suspend Mode

Set the suspend mode. Only available if Power Management function is set to User Define. Settings: *Disable*, *1 Min*, *2 Min*, *4 Min*, *6Min*, *8Min*, *10 Min*, *20 Min*, *30 Min*, *40Min* and *1Hour*.

Wake Up Events

Press <Enter> to enter the sub-menu and the following screen appears:

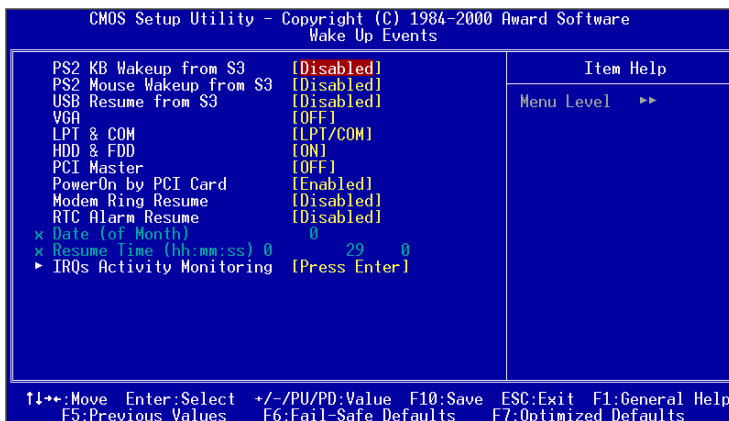

PS2 KB Wakeup from S3

Decide whether to enable PS2 Keyboard wakeup function. Settings: *Disabled* and *Enabled*.

PS2 Mouse Wakeup from S3

Decide whether to enable PS2 Mouse wakeup function. Settings: *Disabled* and *Enabled*.

USB Resume from S3

Decide whether or not the USB devices can wake the system from S3. Settings: *Disabled* and *Enabled*.

VGA

Decide whether or not the power management unit should monitor VGA activities. Settings: *Off* and *ON*.

LPT & COM

Decide whether or not the power management unit should monitor parallel port (LPT) and serial port (COM) activities. Settings: *None*, *LPT*, *COM* and *LPT/COM*.

HDD & FDD

Decide whether or not the power management unit should monitor hard disks and floppy drives activities. Settings: *Off* and *On*.

PCI Master

Decide whether or not the power management unit should monitor PCI master activities. Settings: *Off* and *On*.

PowerOn by PCI Card

Decide whether or not a PCI card can power up the system or resume it from suspend state. Such PCI cards include LAN, onboard USB ports, etc. Settings: *Disabled* and *Enabled*.

Modem Ring Resume

Decide whether or not Ring-In signals from Modem can wake up the system from suspend state. Settings: *Disabled* and *Enabled*.

RTC Alarm Resume

The field is used to enable or disable the feature of booting up the system on a scheduled time/date. Settings: *Disabled* and *Enabled*.

Date (of Month)

The field specifies the date for *RTC Alarm Resume*. Settings: 0~31.

Resume Time (hh:mm:ss)

The field specifies the time for *RTC Alarm Resume*. Format is <hour><minute><second>.

IRQs Activities Monitoring

Press <Enter> to enter the sub-menu and the following screen appears:

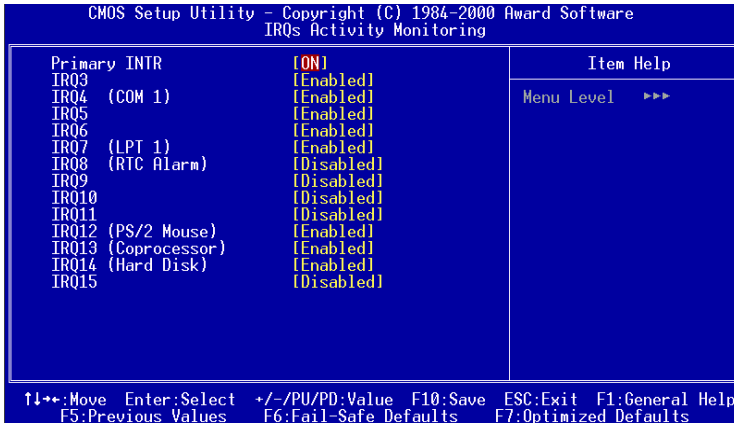

Primary INTR

Selecting *ON* will cause the system to wake up from power saving modes if activity is detected from any enabled IRQ channels.

IRQ3~IRQ15

Enables or disables the monitoring of the specified IRQ line. If set to *Enabled*, the activity of the specified IRQ line will prevent the system from entering power saving modes or awaken it from power saving modes.

Note: *IRQ (Interrupt Request) lines are system resources allocated to I/O devices. When an I/O device needs to gain attention of the operating system, it signals this by causing an IRQ to occur. After receiving the signal, when the operating system is ready, the system will interrupt itself and perform the service required by the IO device.*

PNP/PCI Configurations

This section describes the BIOS configuration of the PCI bus system. This section covers some very technical items and only experienced users should make any changes to the default settings.

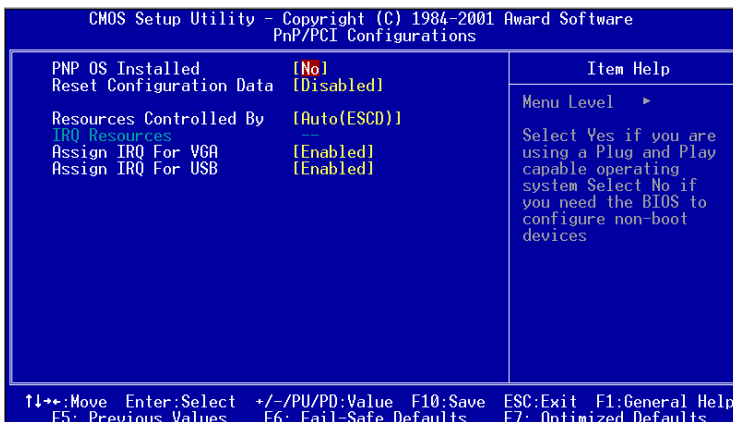

PNP OS Installed

When set to Yes, BIOS will only initialize the PnP cards used for booting (VGA, IDE, SCSI). Other cards will be initialized by the PnP operating system like Windows® 95 or 98/98SE. When set to No, BIOS will initialize all the PnP cards. Set to Yes the operating system is Plug & Play capable. The settings: *No* and *Yes*.

Reset Configuration Data

Normally, you leave this field Disabled. Select Enabled to reset Extended System Configuration Data (ESCD) when you exit Setup if you have installed a new add-on and the system reconfiguration has caused such a serious conflict that the operating system can not boot. The settings: *Enabled* and *Disabled*.

PCI/VGA Palette Snoop

Set the PCI/VGA Palette Snoop option. Settings: *Disabled* and *Enabled*.

Assign IRQ For VGA/USB

Assign IRQ for VGA and USB devices. Settings: *Disabled* and *Enabled*.

Resource Controlled By

The BIOS can automatically configure all the boot and Plug and Play compatible devices. Choose “Auto(ESCD)” if unsure, the BIOS will automatically assign IRQ, DMA and memory base address fields. The settings: *Auto (ESCD)* and *Manual*.

IRQ Resources

The items are adjustable only when *Resources Controlled By* is set to *Manual*. Press <Enter> and you will enter the sub-menu of the items.

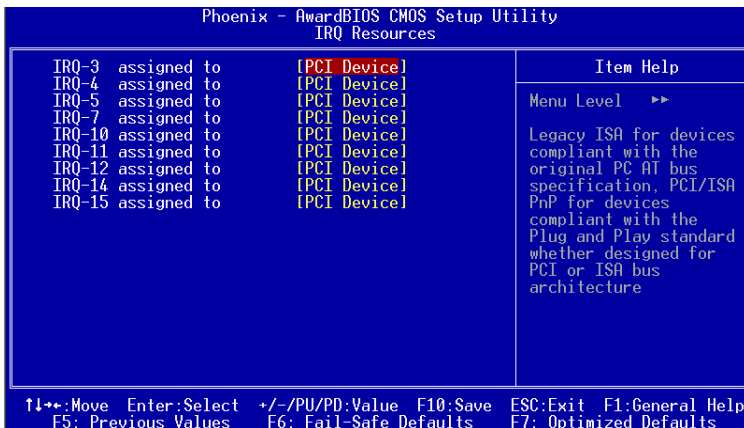

IRQ Resources list IRQ 3/4/5/7/9/10/11/12/14/15 for users to set each IRQ a type depending on the type of device using the IRQ. Settings:

- PCI/ISA PnP* For Plug & Play compatible devices designed for PCI and ISA bus architecture.
- Legacy ISA* For Legacy ISA device.

DMA Resources

The items are adjustable only when *Resources Controlled By* is set to *Manual*. Press <Enter> and you will enter the sub-menu of the items.

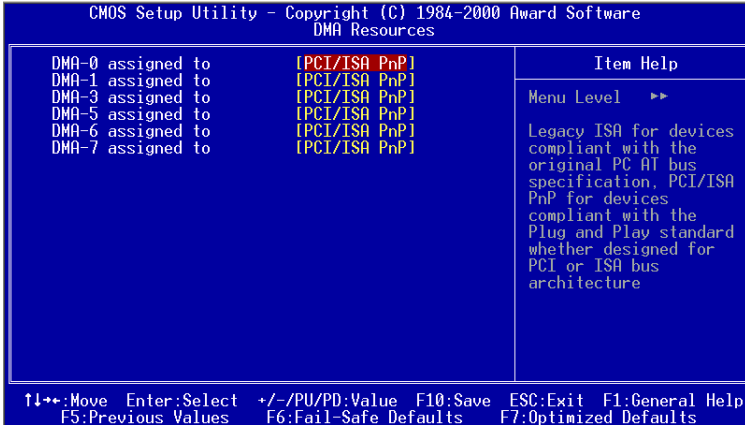

Resources list DMA 0/1/3/5/6/7 for users to set each DMA channel type. Settings:

PCI/ISA PnP For Plug & Play compatible devices designed for PCI bus architecture.

Legacy ISA For Legacy ISA device.

PC Health Status

This section shows the status of your CPU, fan, warning for overall system status.

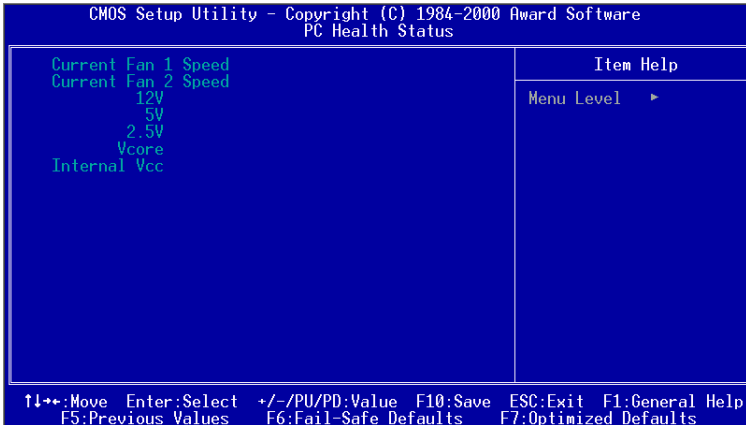

CPU Fan Speed, CPU Fan 2 Speed, 12V, 5V, 2.5V, Vcore and Internal VCC.

These items display the current status of all of the monitored hardware devices/components such as fan speed.

Load Fail-Safe Defaults

This option on the main menu allows users to restore all the BIOS settings to the default Fail Safe values. These values are set by the mainboard manufacturer to provide the most stable system.

When you select Load-Fail Safe Defaults, a message as below appears:

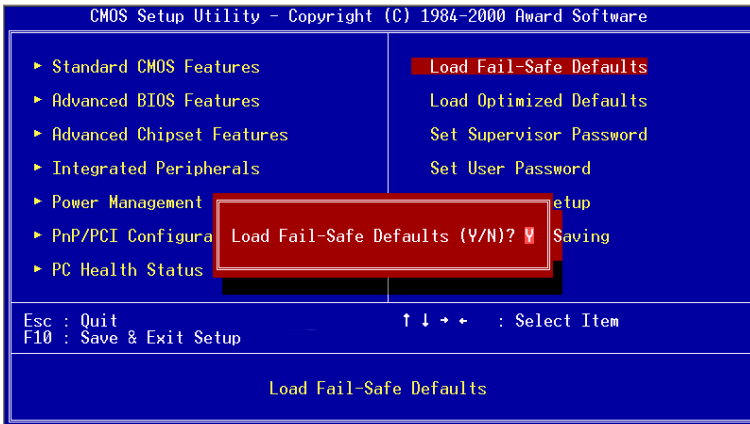

Pressing “Y” loads the default BIOS values that provide a minimal and stable system configuration.

Load Optimized Defaults

This option on the main menu allows users to restore all the BIOS settings to the default Optimized values. The Optimized Defaults are the default values also set by the mainboard manufacturer for both optimized and stable performance of the mainboard.

When you select Load Optimized Defaults, a message as below appears:

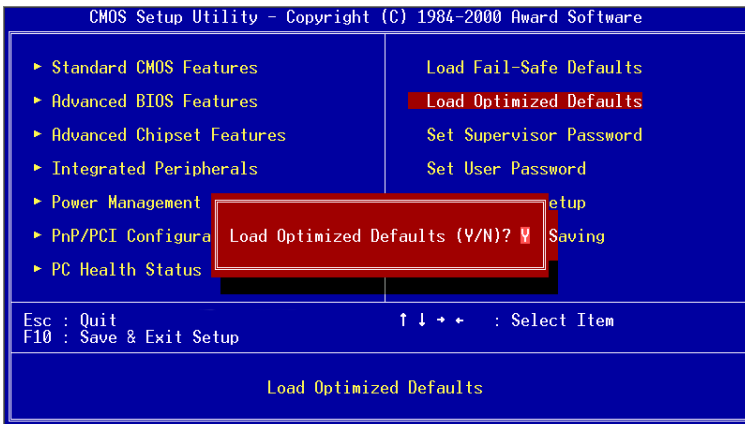

Pressing “Y” loads the default values that are factory settings for optimal and stable system performance.

Set Supervisor/User Password

When you select this function, a message as below will appear on the screen:

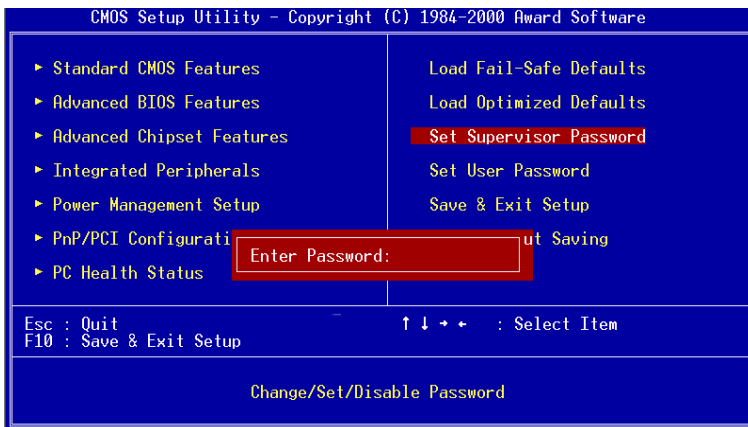

Type the password, up to eight characters in length, and press <Enter>. The password typed now will clear any previously set password from CMOS memory. You will be prompted to confirm the password. Re-type the password and press <Enter>. You may also press <Esc> to abort the selection and not enter a password.

To clear a set password, just press <Enter> when you are prompted to enter the password. A message will show up confirming that the password will be disabled. Once the password is disabled, the system will boot and you can enter Setup without entering any password.

When a password has been set, you will be prompted to enter it every time you try to enter Setup. This prevents an unauthorized person from changing any part of your system configuration.

Additionally, when a password is enabled, you can also have BIOS to request a password each time the system is booted. This would prevent unauthorized use of your computer. The setting to determine when the password prompt is required is the Security Option of the Advanced BIOS Features menu. If the Security Option is set to *System*, the password is required both at boot and at entry to

Setup. If set to *Setup*, password prompt only occurs when trying to enter Setup.

About Supervisor Password & User Password:

Supervisor password: Can enter and change the settings of the setup menus.

User password: Can only enter but do not have the right to change the settings of the setup menus.

Save & Exit Setup

When you want to quit the Setup menu, you can select this option to save the changes and quit. A message as below will appear on the screen:

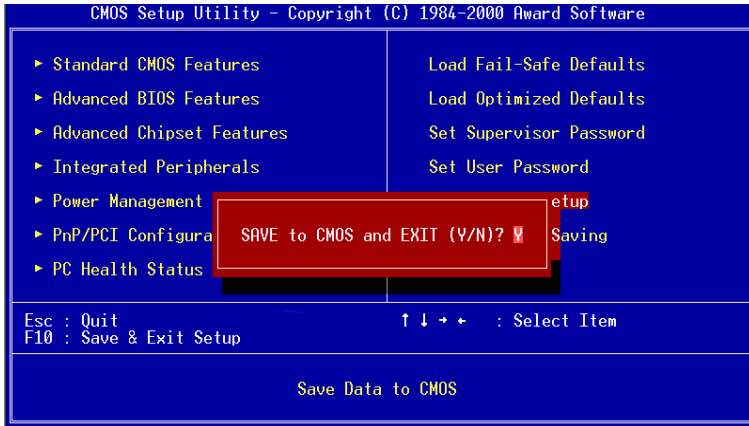

Typing “Y” will allow you to quit the Setup Utility and save the user setup changes to RTC CMOS.
Typing “N” will return to the Setup Utility.

Exit Without Saving

When you want to quit the Setup menu, you can select this option to abandon the changes. A message as below will appear on the screen:

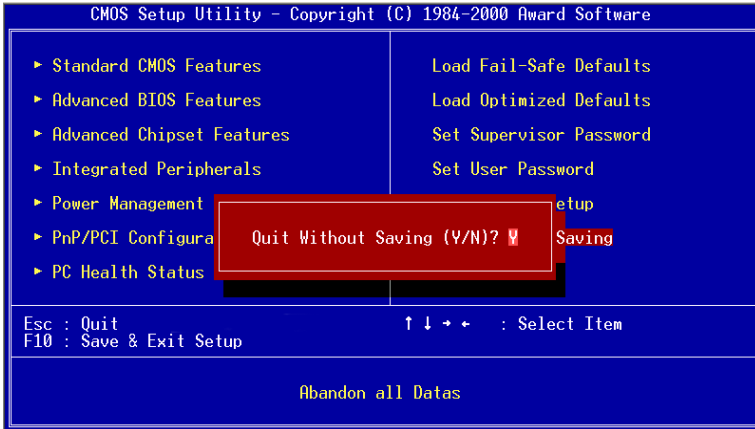

Typing “Y” will allow you to quit the Setup Utility without saving any changes to RTC CMOS.

Typing “N” will return to the Setup Utility.

4. Software Setup

This chapter gives you detailed instructions on setup of motherboard drivers and applications. It consists of the following topics:

VIA Apollo PLE133 Chipset Drivers	4-2
VIA PLE133 Integrated VGA Driver	4-12
VIA Audio Driver	4-14
VIA Network Driver	4-15
VIA Fast InfraRed Driver	4-30

Note: You must install VIA 4in1 chipset driver first before installing other drivers like audio or VGA drivers. The applications will only function correctly if the necessary drivers are already installed.

VIA Apollo PLE133 Chipset Drivers

The VIA PLE133 chipset is a highly integrated, cost-effective and energy efficient SMA chipset. Featuring the Apollo PLE133 graphics controller with highly integrated display control device that includes a video accelerator with advanced DVD video and TV output capability.

System Requirements

Monitor	VGA Support, minimum 640 x 480 resolution
Operating system	Windows® 95/98/98SE, Windows® NT3.51 or 4.0, Windows® ME, Windows® 2000, or Windows® XP
CD-ROM	Double speed or higher
Chipset	VIA Apollo PLE133 chipset

4in1 chipset driver installation for Windows XP

1. Insert the supplied CD into the CD-ROM drive.
2. The CD should run automatically and the setup screen will appear. If not, please run the “setup.exe” within the CD manually.
3. On the setup screen click the **Install VIA Chipset Drivers** option to install the **VIA Service Pack 4**.

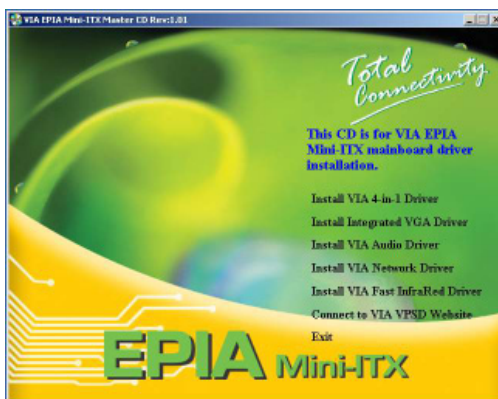

4. When the installation starts, click **Next** to view the **VIA Service Pack README**.
5. Click **Yes** to proceed.
6. The screen now will show two installation options. Select **Normally Install** to manually install every driver, else select **Quickly Install** to install the drivers automatically. Click **Next** to continue, for **Quickly Install** users please go to step 9.

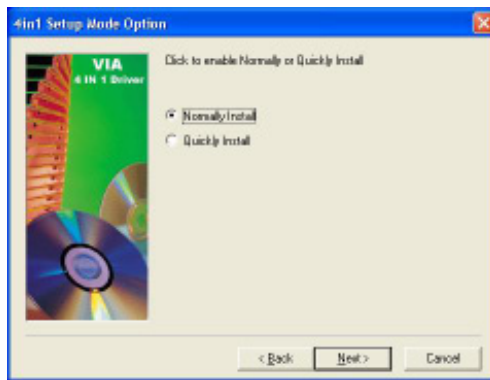

7. The screen shows two drivers:
VIA PCI IDE Bus Driver
VIA INF Driver

Please select the driver and click **Next** to continue.

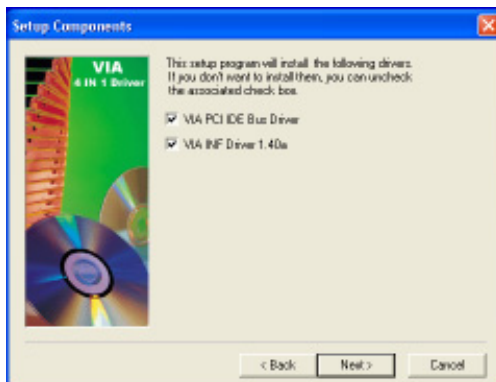

8. The screen now should show one driver: **Install VIA PCI IDE Bus Driver**. Please select the driver and click on **Next** to continue.

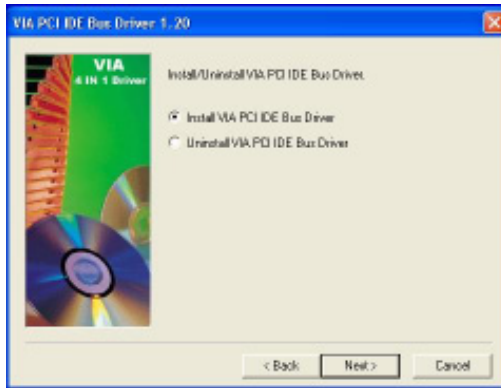

9. After all chipset drivers are properly installed please select “**Yes, I want to restart my computer now.**” and click **Finish** to restart your computer and complete the installation.

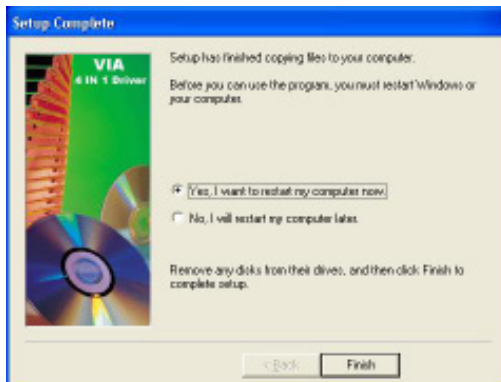

4in1 chipset driver installation for Windows 2000

1. Insert the supplied CD into the CD-ROM drive.
2. The CD should run automatically and the setup screen will appear. If not, please run the “setup.exe” within the CD manually.
3. On the setup screen click on the **Install VIA Chipset Drivers** option to install the **VIA Service Pack 4**.
4. When the installation starts, click **Next** to view the **VIA Service Pack README**.
5. Click **Yes** to proceed.
6. The screen now will show two installation options. Select **Normally Install** to manually install every driver, else select **Quickly Install** to install the drivers automatically. Click **Next** to continue, for **Quickly Install** users please go to step 10.
7. The screen now should show three drivers:
 - VIA PCI IDE Bus Driver.**
 - AGP VxD Driver.**
 - VIA INF Driver.**

Please select all three drivers and click **Next** to continue.

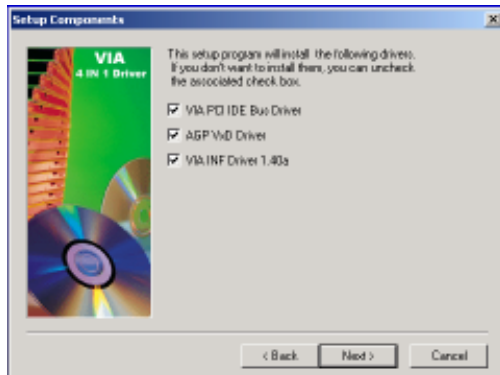

Chapter 4

8. Select **Install VIA PCI IDE Bus Driver** and click **Next** to continue.

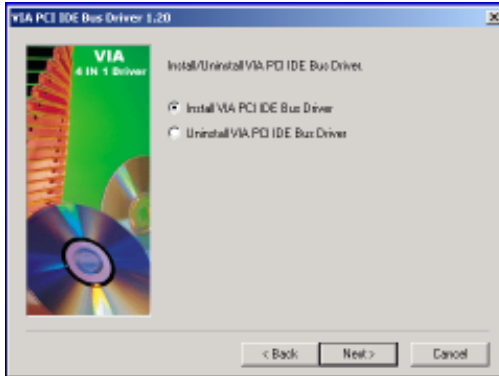

9. Select **Install AGP 4X/133 driver** and click **Next** to continue.

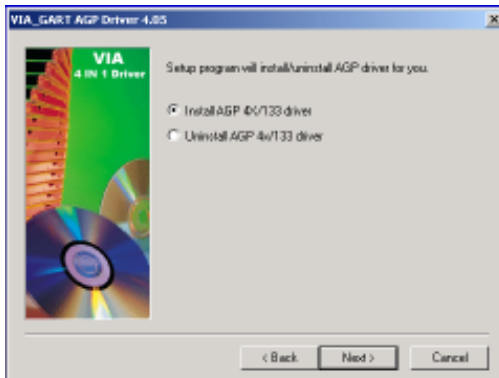

10. After all chipset drivers are properly installed please select “**Yes, I want to restart my computer now.**” and click **Finish** to restart your computer and complete the installation.

4in1 chipset driver installation for Windows 98/98SE

1. Insert the supplied CD into the CD-ROM drive.
2. The CD should run automatically and the setup screen will appear. If not, please run the “setup.exe” within the CD manually.
3. On the setup screen click on the **Install VIA Chipset Drivers** option to install the **VIA Service Pack 4**.



4. When the installation starts, click **Next** to view the **VIA Service Pack README**.
5. Click **Yes** to proceed.

6. The screen now will show two installation options. Select **Normally Install** to manually install every driver, else select **Quickly Install** to install the drivers automatically. Click **Next** to continue, for **Quickly Install** users please go to step 12.

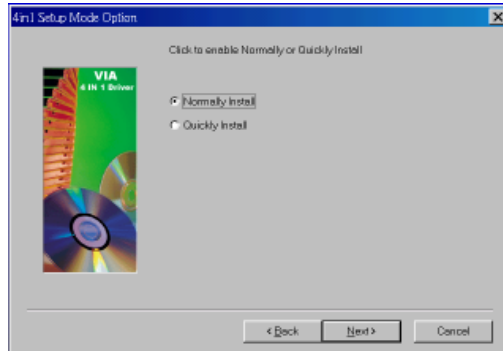

7. The screen will now show four drivers:
VIA ATAPI Vendor Support Driver.
AGP VxD Driver.
IRQ Routing Miniport Driver.
VIA INF Driver.

Please select all four drivers and click **Next** to continue.

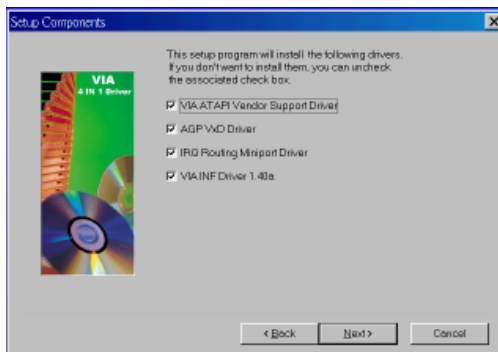

8. Select **Install VIA ATAPI Vendor Support Driver** and click **Next** to continue.

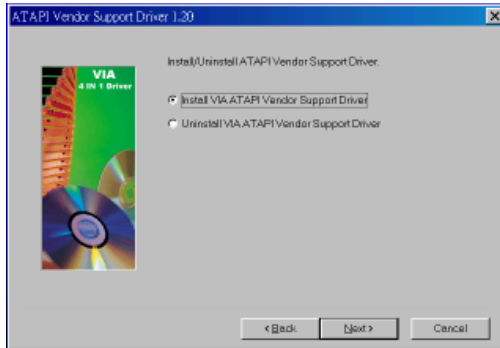

9. Select **Click to enable DMA Mode** option and click **Next** to continue.
10. Select **Install VIA AGP VxD in Turbo mode** and click **Next** to continue.

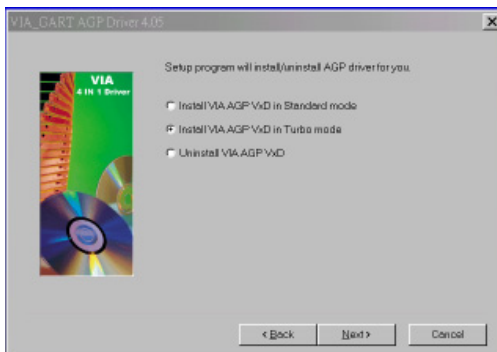

11. Select **Install VIA IRQ Routing Miniport Driver** and click **Next** to continue.

12. After all chipset drivers are properly installed please select "**Yes, I want to restart my computer now.**" and click **Finish** to restart your computer and complete the installation.

4in1 chipset driver installation for Windows ME

1. Insert the supplied CD into the CD-ROM drive.
2. The CD should run automatically and the setup screen will appear. If not, please run the “setup.exe” within the CD manually.
3. On the setup screen click on the **Install VIA Chipset Drivers** option to install the **VIA Service Pack 4**.
4. When the installation starts, click **Next** to view the **VIA Service Pack README**.
5. Click **Yes** to proceed.
6. The screen now will show two installation options. Select **Normally Install** to manually install every driver, else select **Quickly Install** to install the drivers automatically. Click **Next** to continue, for **Quickly Install** users please go to step 11.
7. The screen now should show three drivers:
 - VIA ATAPI Vendor Support Driver.**
 - AGP VxD Driver.**
 - VIA INF Driver.**

Please select all three drivers and click **Next** to continue.

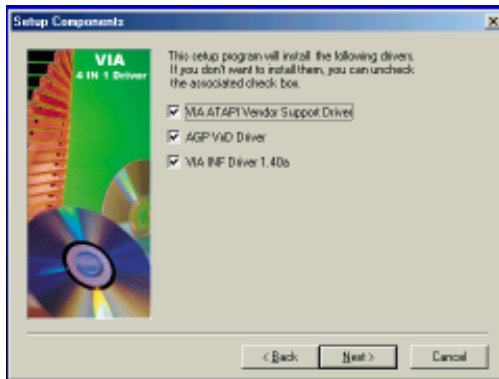

8. Select **Install VIA ATAPI Vendor Support Driver** and click **Next** to continue.

9. Select **Click to enable DMA Mode** option and click **Next** to continue.

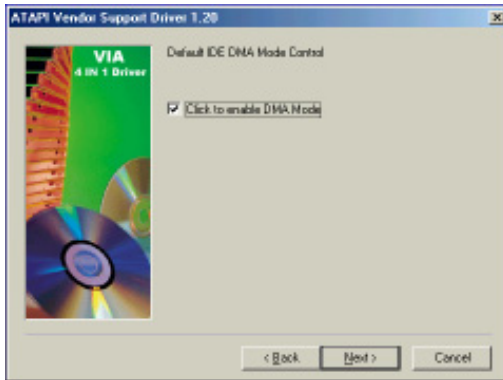

10. Select **Install VIA AGP VxD in Turbo mode** and click **Next** to continue.

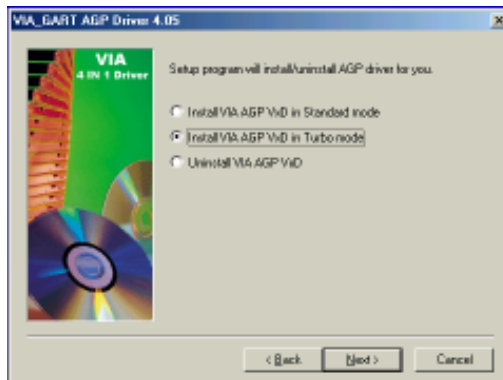

11. After all chipset drivers are properly installed please select “**Yes, I want to restart my computer now.**” and click **Finish** to restart your computer and complete the installation.

VIA PLE133 Integrated VGA Driver

VGA driver installation for Windows 98/98SE/ME/2000/XP

1. Insert the supplied CD into the CD-ROM drive.
2. The CD should run automatically and the setup screen will appear. If not, please run the “setup.exe” within the CD manually.
3. On the setup screen click on the **Install Integrated VGA Driver** option.



4. Install VIA Tech KLE/PLE Display Driver.

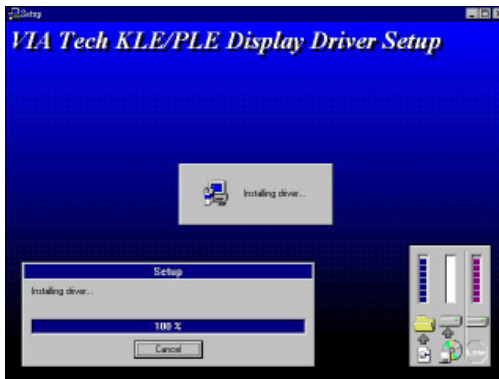

5. After the VGA driver is properly installed, please select “**Yes, I want to restart my computer now.**” And click **Finish** to restart your computer and complete the installation.



VIA Audio Driver

Audio driver installation for Windows 98/98SE/ME/2000/XP

1. Insert the supplied CD disc into the CD-ROM drive.
2. The CD should run automatically and the setup screen will appear. If not, please run the “setup.exe” within the CD manually.
3. On the setup screen click the **Install VIA Audio Driver**.



4. Select Install driver. Click **Next** to continue.

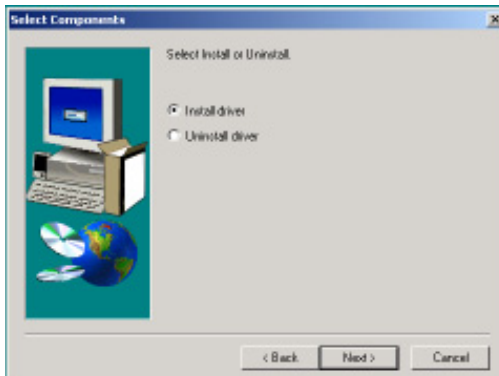

5. After the audio driver is installed, select “**Yes, I want to restart my computer now**”. Click **Finish** to restart your computer (Windows ME only).

VIA Network Driver

Network driver installation for Windows XP

1. Put the supplied CD into the CD ROM drive and double click “**System**” in the “**Control Panel**”.

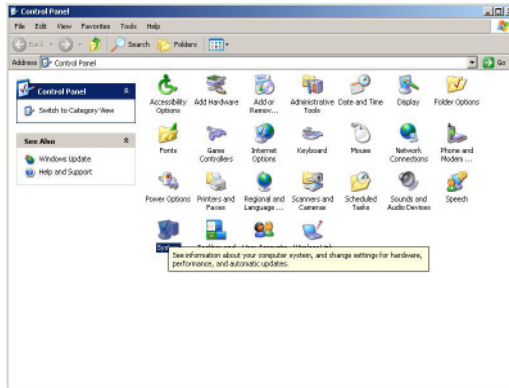

2. The “**System Properties**” window is popped. Select the “**Hardware**” tab. And click the “**Device Manager**” button.

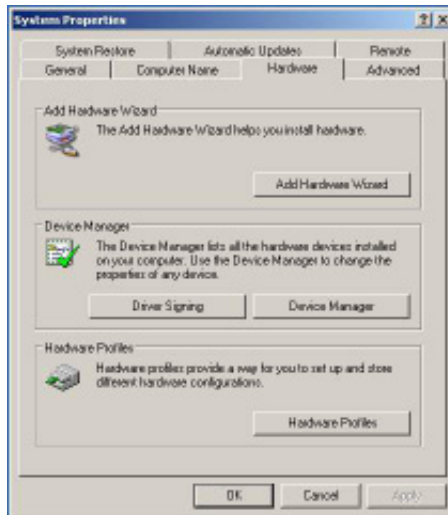

Chapter 4

3. The “**Device Manager**” window is popped. Then, select the “**VIA PCI 10/100Mb Fast Ethernet Adapter**” and click right button to select the “**Properties**”.

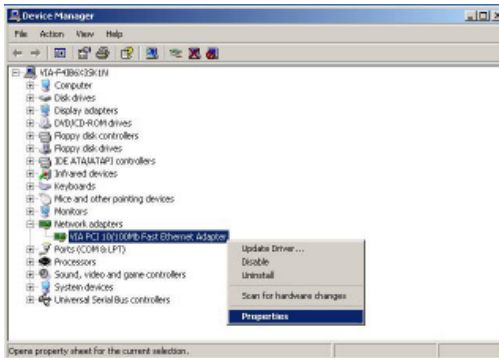

4. In the “**VIA PCI 10/100Mb Fast Ethernet Adapter Properties**” window, select “**Update Driver**” button.

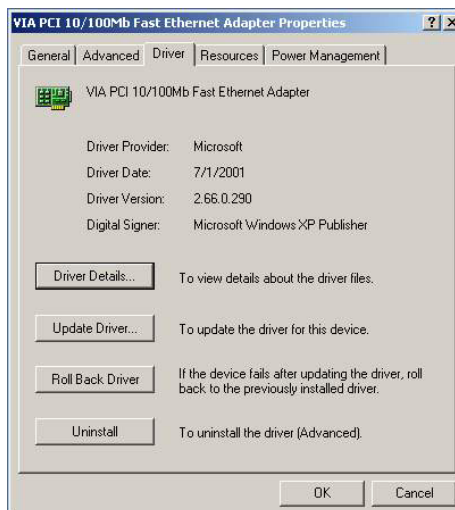

5. Once the “**Update Device Driver Wizard**” is invoked. Select “**Next**” to continue.



6. Select “**Don’t search, I will choose the driver to install**” and click “**Next**” button to continue.

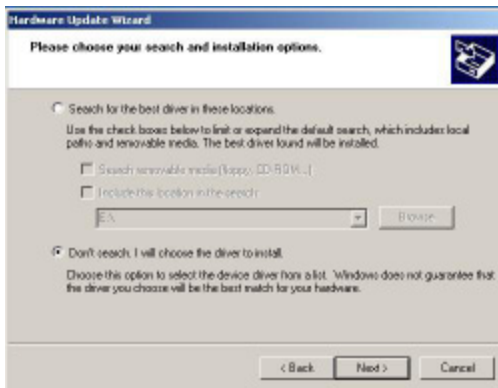

7. Select “**VIA PCI 10/100Mb Fast Ethernet Adapter**” for driver and click “**Have Disk...**” to find driver location.

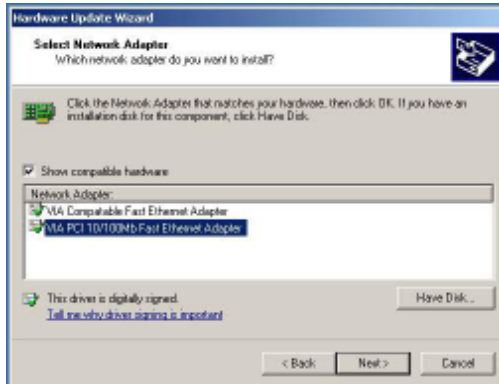

8. Click “**Browse**” button to find driver location. In this case, the driver is in “**E:\DRIVERS\LAN**”. Then click “**OK**” to continue.



9. Find the suitable device “**VIA 10/100Mb Fast Ethernet Adapter**” from the location E:\Drivers\LAN, and click “**Next**” button to continue.

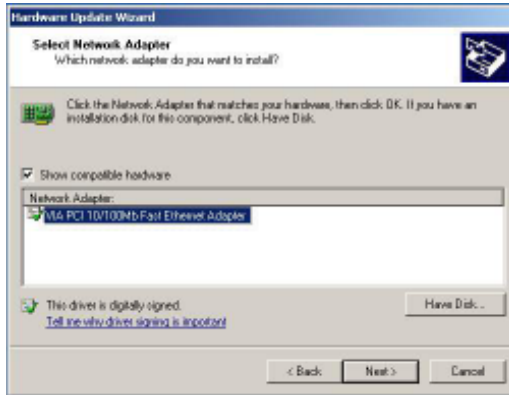

10. Complete upgrading the driver and click “**Finish**” to close wizard.



Network driver installation for Windows 2000

1. Put the supplied CD in the CD ROM drive and click the “**Start**”, “**Setting**” and “**Control Panel**” sequentially. And double click “**System**”.

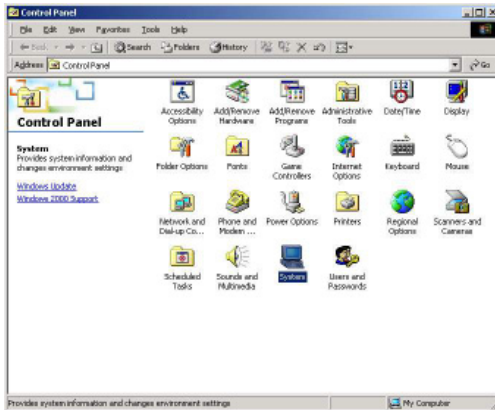

2. The “**System Properties**” window is popped. Select the “**Hardware**” tab (left click the tab), then click the “**Device Manager**” button.

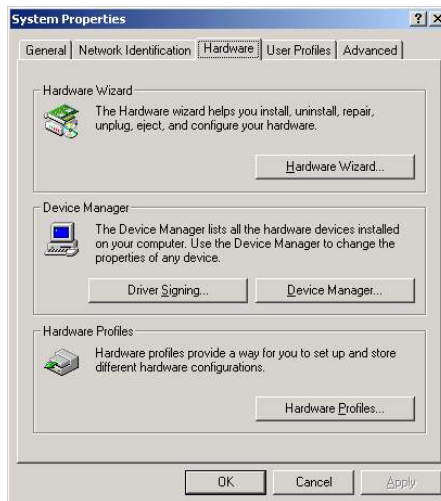

3. The “**Device Manager**” window is popped. Then, select the “**Ethernet controller**” and click right mouse button, and select the “**Properties**”.

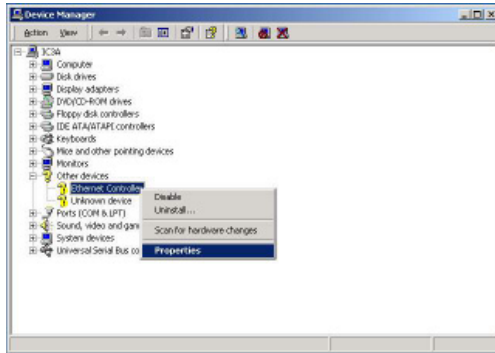

4. In the “**Ethernet Controller Properties**” window. Select “**Reinstall Driver**” button.

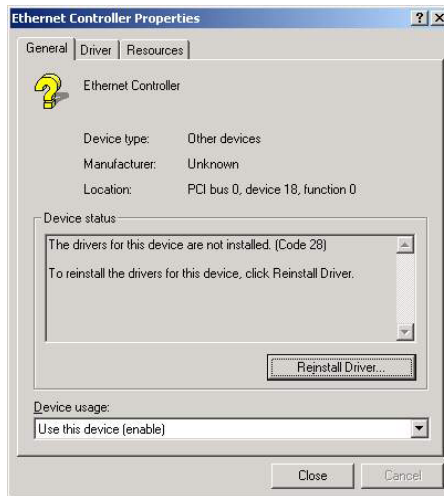

5. The “**Update Device Driver Wizard**” is invoked. Select “**Next**” to continue.

6. Select “**Search for a suitable driver for my device [recommended]**” and click “**Next**” to continue.



7. Select “**Specify a location**” for driver and click “**Next**” to continue.



8. Click “**Browse**” button to find driver location. In this case, the driver is in “**E:\DRIVERS\LAN**”. Then click “**OK**” to continue.



9. Find the suitable driver from the location “**E:\Drivers\LAN**”, and click “**Next**” to continue.

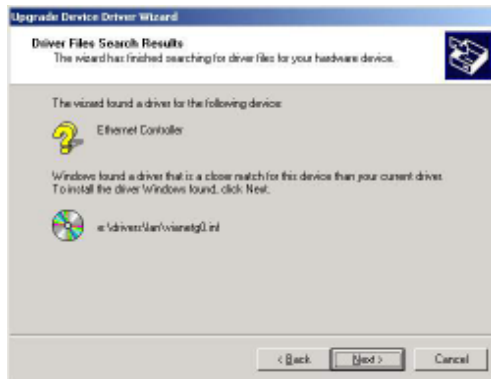

10. Completing the Upgrade Device Driver and click “**Finish**” to close wizard.

Network driver installation for Windows 98/98SE

1. Put the supplied CD in the CD ROM drive and right click the “**My Computer**” icon on the desktop. Move mouse pointer to “**Properties**” item and left click it.

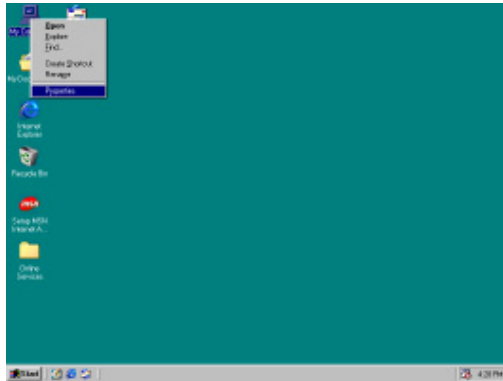

2. The “**System Properties**” window is popped. Select the “**Device Manager**” tab (left click the tab), then select the “**PCI Ethernet Controller**” and click the “**Properties**” button.

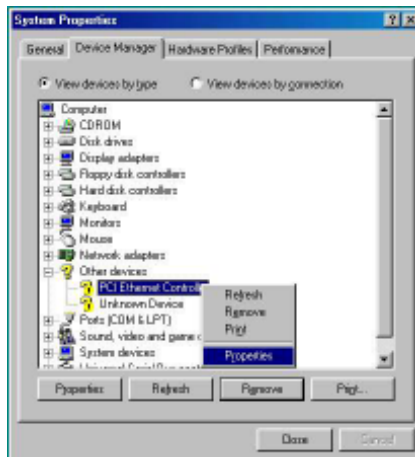

3. In the “**PCI Ethernet Controller Properties**” window, click the “**Reinstall Driver**” button.

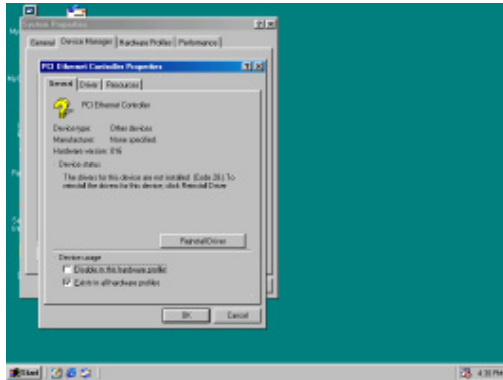

4. The “**Update Device Driver Wizard**” is invoked, then click “**Next**” to continue.
5. Select “**Search for a better driver than the one your device is using now. [Recommended]**” item and click “**Next**” to continue.



Chapter 4

6. Click **“Browse”** to find driver location. In this case, the driver is in **“E:\DRIVERS\LAN”**. Then click **“Next”** to continue.



7. Completing the Upgrade Device Driver and click **“Finish”** to close wizard.

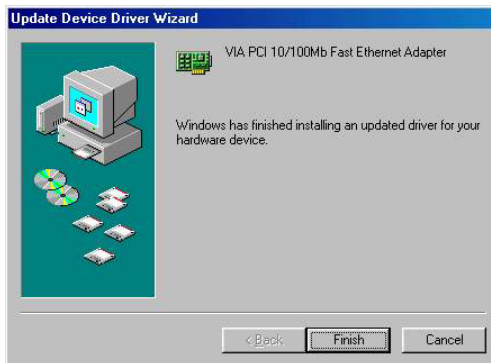

Network driver installation for Windows ME

1. Put the supplied CD in the CD ROM drive and right click the “**My Computer**” icon on the desktop. Move mouse pointer to “**Properties**” item and left click it.

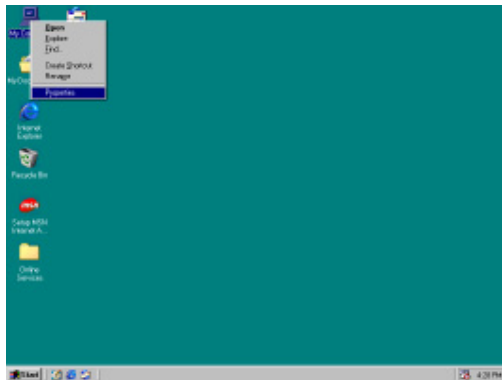

2. The “**System Properties**” window is popped. Select the “**Device Manager**” tab (left click the tab), then select the “**VIA PCI 10/100Mb Fast Ethernet Adapter**” and click the “**Properties**” button.

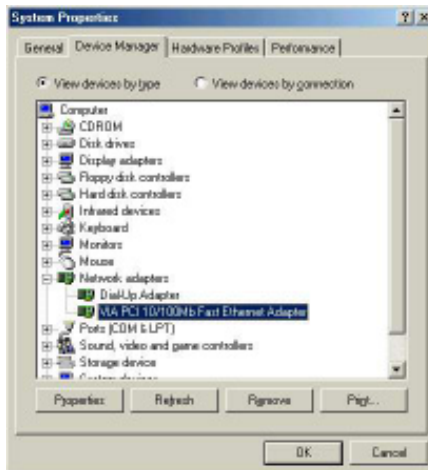

Chapter 4

3. In the “VIA PCI 10/100Mb Fast Ethernet Adapter Properties” window, select the “Driver” tab and click the “Update Driver” button.



4. The “Update Device Driver Wizard” is invoked. Select “Specify the location of the driver [Advanced]” and click “Next” to continue.



5. Select “Search for a better driver than the one your device is using now. [Recommended]” and use “Browse” button to specify a location: E:\DRIVERS\LAN”. Then click “Next” to continue.



6. Select “The updated driver [Recommended] VIA PCI 10/100Mb Fast Ethernet Adapter” to update new driver. Then click “Next” to continue.



7. Click “Next” of the “Update Device Driver Wizard” dialog.

8. Then click “Finish” of the “Update Device Driver Wizard” dialog.

VIA Fast InfraRed Device Driver

VIA Fast InfraRed Device Driver installation for Windows XP

1. Put the supplied CD into the CD ROM drive and double click “**System**” in the “**Control Panel**”.

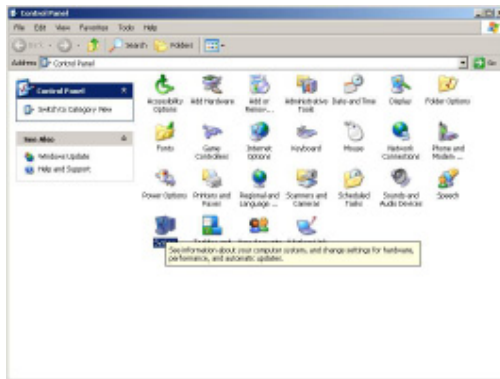

2. The “**System Properties**” window is popped. Select the “**Hardware**” tab. And click the “**Device Manager**” button.

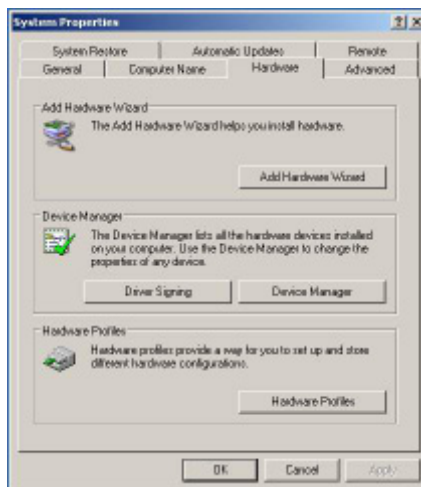

3. The “**Device Manager**” window is popped. Then, select the “**VIA Fast InfraRed Controller**” and click right button to select the “**Properties**”.

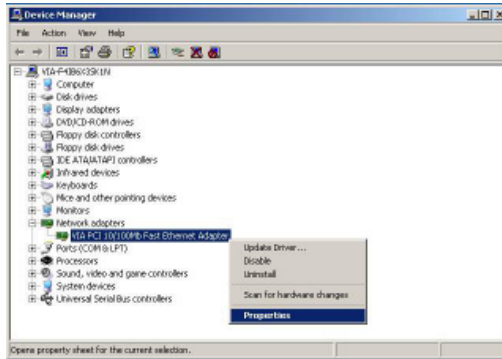

4. In the “**VIA Fast InfraRed Controller Properties**” window, select “**Update Driver**” button.

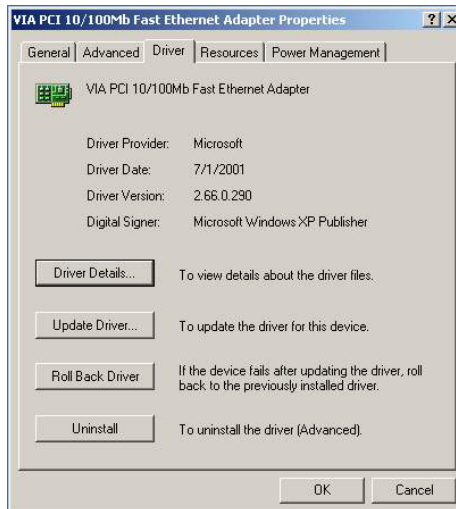

5. Once the “**Update Device Driver Wizard**” is invoked. Select “**Next**” to continue.



6. Select “**Don’t search, I will choose the driver to install**” and click “**Next**” button to continue.

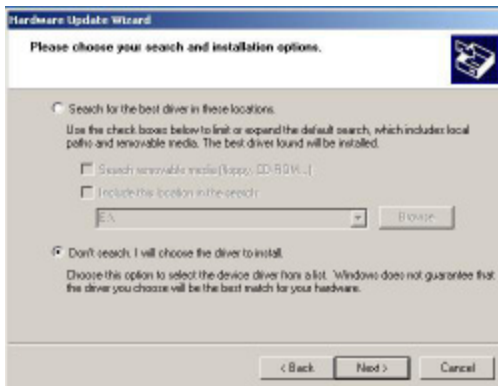

7. Select “**VIA Fast InfraRed Controller**” for driver and click “**Have Disk...**” to find driver location.

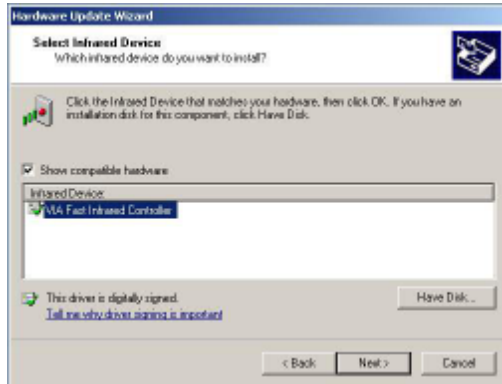

8. Click “**Browse**” button to find driver location. In this case, the driver is in “**E:\DRIVERS\FIR\WINXP**”. Then click “**OK**” to continue.

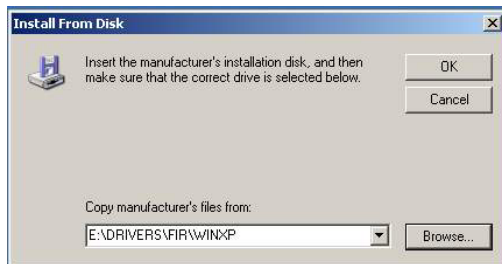

Chapter 4

9. Find the suitable device “**VIA Fast InfraRed Controller**” from the location, and click “**Next**” button to continue.

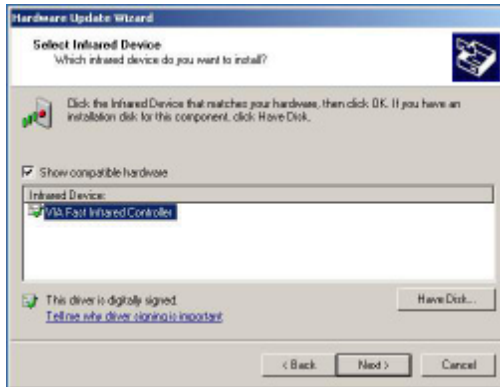

10. Complete upgrading the driver and click “**Finish**” to close wizard.



VIA Fast InfraRed Device Driver installation for Windows 2000

1. Put the supplied CD into the CD ROM drive and double click “System” in the “Control Panel”.

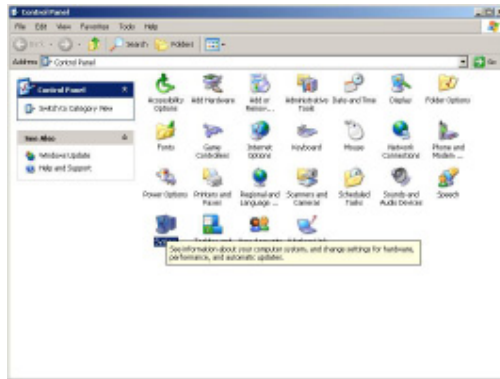

2. The “System Properties” window is popped. Select the “Hardware” tab. And click the “Device Manager” button.

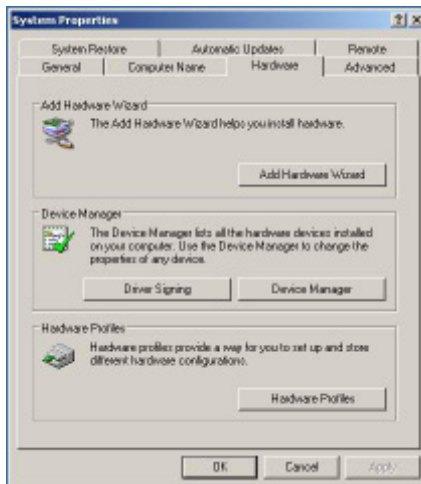

3. The “**Device Manager**” window is popped. Then, select the “**Unknown device**” and click right button to select the “**Properties**”.

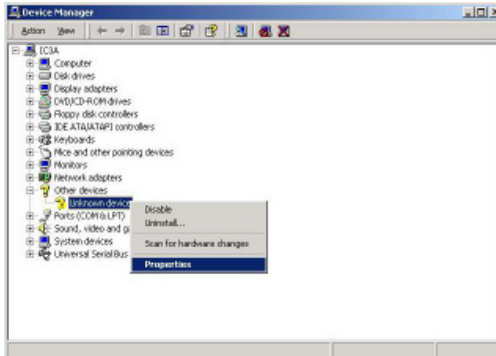

4. In the “**Unknown device Properties**” window, select “**Reinstall Driver**” button.



5. The “**Update Device Driver Wizard**” is invoked. Click “**Next**” to continue.

6. Select **“Search for suitable driver for my device [recommended]”** and click **“Next”** to continue.



7. Select **“Specify a location”** for driver. Then click **“Next”** to continue.



8. Click “**Browse**” to find driver location. In this case, the driver is in supplied CD under “**E:\DRIVERS\FIR\WIN2000**”. Click “**OK**” to continue.



9. Find the suitable driver from the location and click “**Next**” to continue.
10. Completing the “**Upgrade Device Driver Wizard**” and click “**Finish**” to close wizard.



VIA Fast InfraRed Device Driver installation for Windows 98/98SE

1. Put the supplied CD into the CD ROM drive and double click “**System**” in the “**Control Panel**”.
2. The “**System Properties**” window is popped. Select the “**Device Manager**” tab (left click the tab), then select the “**PCI Ethernet Control**” and click the “**Properties**” button.

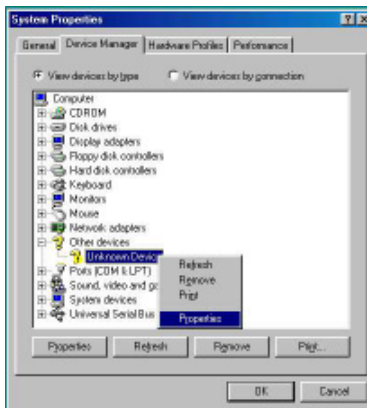

3. In the “**Unknown Device Properties**” window. Select “**General**” tab and click the “**Reinstall Driver**” button.



4. The “**Add New Hardware Wizard**” is invoked and click “**Next**” to continue.
5. Select “**Search for a better driver than the one your device is using now. [Recommended]**” and click “**Next**” to continue.



6. Specify the location of the driver by clicking on “**Browse**” button. The location should be “**E:\DRIVERS\FIR\WIN98SE**”. Then click the “**Next**” button.



7. Click “**Next**” in the “**Add New Hardware Wizard**” dialog.
8. Click “**Finish**” to close wizard and complete the driver installation.

VIA Fast InfraRed Device Driver installation for Windows ME

1. Put the supplied CD into the CD ROM drive and double click “**System**” in the “**Control Panel**”.
2. The “**System Properties**” window is popped. Select the “**Device Manager**” tab (left click the tab), then select the “**PCI Ethernet Control**” and click the “**Properties**” button.
3. In the “**Unknown Device Properties**” window. Select “**General**” tab and click the “**Reinstall Driver**” button.
4. The “**Update Device Driver Wizard**” is invoked. Select “**Specify the location of the driver [Advanced]**” and click the “**Next**” button.



5. Select “**Search for a better driver than the one your device is using now. [Recommended]**” and click “**Browse**” to set the location to CD-ROM drive under directory “**E:\DRIVERS\FIR\WINME**”. Click “**Next**” to continue.



6. Click “**Next**” in the “**Update Device Driver Wizard**” dialog.



8. Click “**Finish**” to close wizard and complete the driver installation.