

HN62414 Series

HN62434 Series

4M (256K x 16-bit) and (512K x 8-bit) Mask ROM

DESCRIPTION

The Hitachi HN62414/HN62434 Series is a 16-Megabit CMOS Mask Programmable Read Only Memory organized as 262,144 x 16-bit and 524,288 x 8-bit.

The low power consumption of this device makes it ideal for battery powered, portable systems. In addition, the high density and high speed provide enough capacity and high performance to be used as a character generator in laser printers.

Hitachi's HN62414/HN62434 Series is offered with JEDEC-Standard pinouts in 40-pin Plastic DIP and 40-lead Plastic SOP packages as well as 44-lead Plastic QFP and TQFP, 48-lead Plastic SOP and 64-lead Plastic QFP packages.

FEATURES

- Single Power Supply:
 $V_{CC} = 5 V \pm 10\%$
- Fast Access Times:
 150 ns/170 ns/200 ns (max)
- Low Power Consumption:
 Active Current: 100 mW (typ)
 Standby Current: 5 μ W (typ)
- User Selectable Organization:
 256K x 16-bit (Word-Wide)
 512K x 8-bit (Byte-Wide)
 Switchable with BHE pin
- TTL-Compatible Inputs and Outputs
- Three-State Data Outputs
- Pin Arrangements:
 JEDEC Standard
- Packages:
 40-pin Plastic DIP
 40-lead Plastic SOP
 44-lead Plastic QFP
 44-lead Plastic TQFP
 48-lead Plastic SOP
 64-lead Plastic QFP

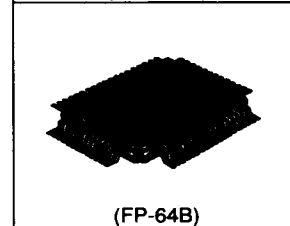
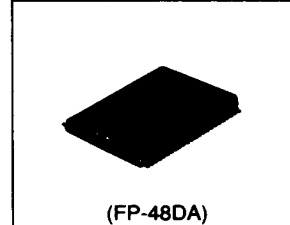
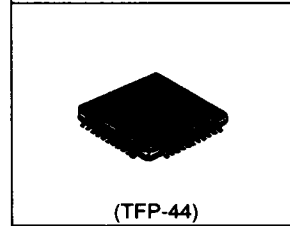
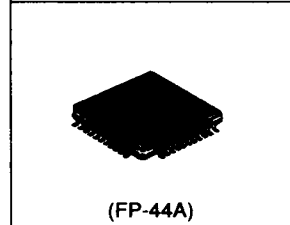
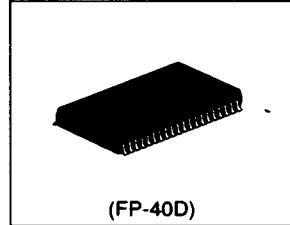
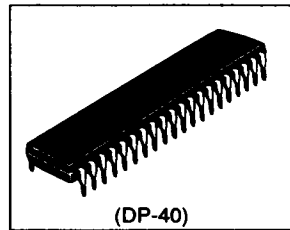

HITACHI

Hitachi America, Ltd. • 2000 Sierra Point Pkwy. • Brisbane, CA 94005-1819 • (415) 589-8300

5-27

5

■ **ORDERING INFORMATION**

Type No.	Access Time	Package
HN62434/414P-15	150 ns	40-pin Plastic DIP (DP-40)
HN62434/414P-17	170 ns	
HN62434/414P-20	200 ns	
HN62434/414FA-15	150 ns	40-lead Plastic SOP (FP-40D)
HN62434/414FA-17	170 ns	
HN62434/414FA-20	200 ns	
HN62434/414FP-15	150 ns	44-lead Plastic QFP (FP-44A)
HN62434/414FP-17	170 ns	
HN62434/414FP-20	200 ns	
HN62434/414TFP-15	150 ns	44-lead Plastic TQFP (TFP-44)
HN62434/414TFP-17	170 ns	
HN62434/414TFP-20	200 ns	
HN62434/414F-15	150 ns	48-lead Plastic SOP (FP-48DA)
HN62434/414F-17	170 ns	
HN62434/414F-20	200 ns	
HN62434/414FS-15	150 ns	64-lead Plastic QFP (FP-64B)
HN62434/414FS-17	170 ns	
HN62434/414FS-20	200 ns	

■ **PIN ARRANGEMENT**

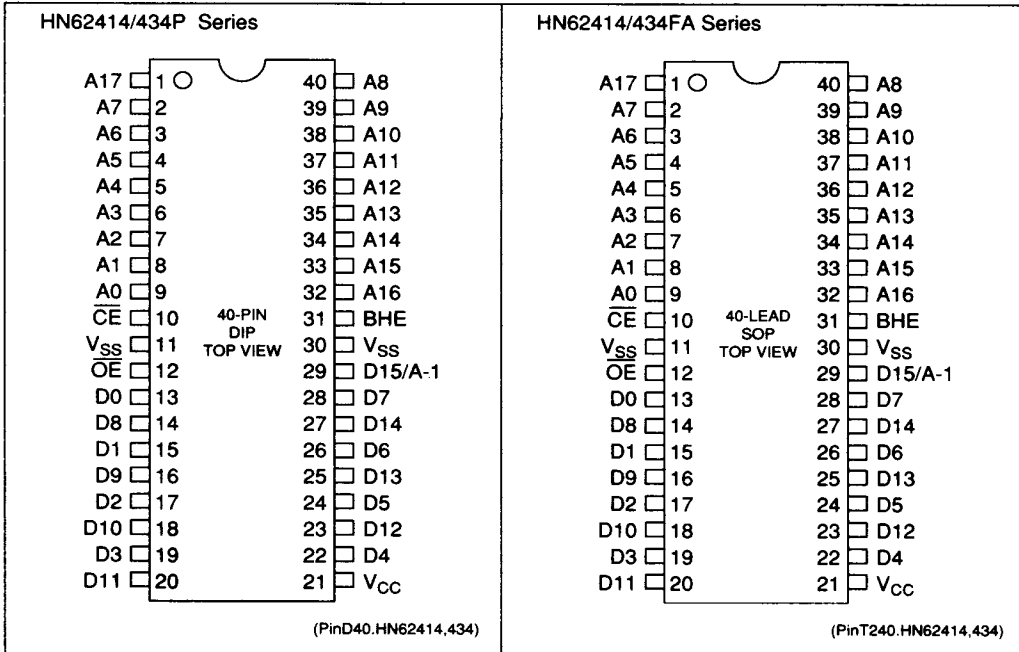

HITACHI

■ PIN ARRANGEMENT (cont.)

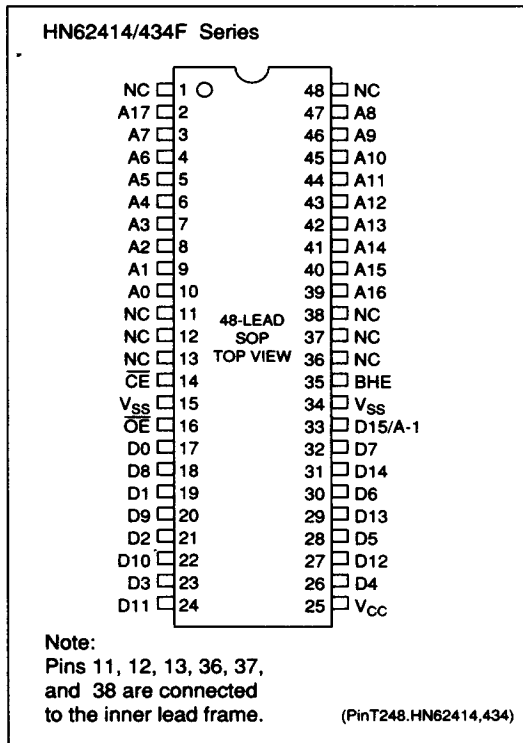

■ PIN DESCRIPTION

Pin Name	Function
A ₀ - A ₁₇	Address
A ₋₁	Address (Word-Wide)
D ₀ - D ₁₅	Output
CE	Chip Enable
OE	Output Enable
BHE	Byte Enable
V _{cc}	Power Supply
V _{ss}	Ground
NC	No Connection

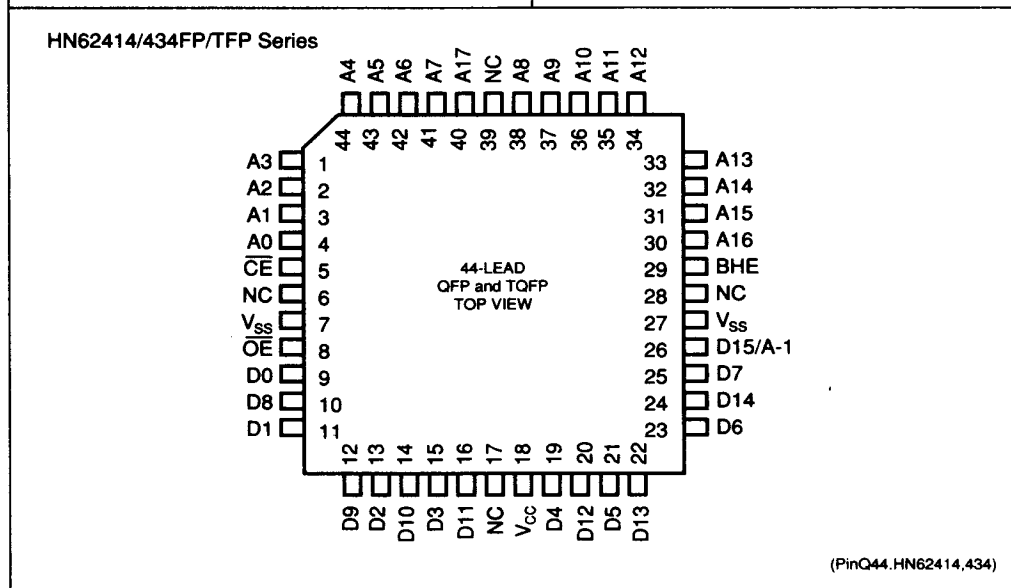

HITACHI

Hitachi America, Ltd. • 2000 Sierra Point Pkwy. • Brisbane, CA 94005-1819 • (415) 589-8300

5-29

■ PIN ARRANGEMENT (cont.)

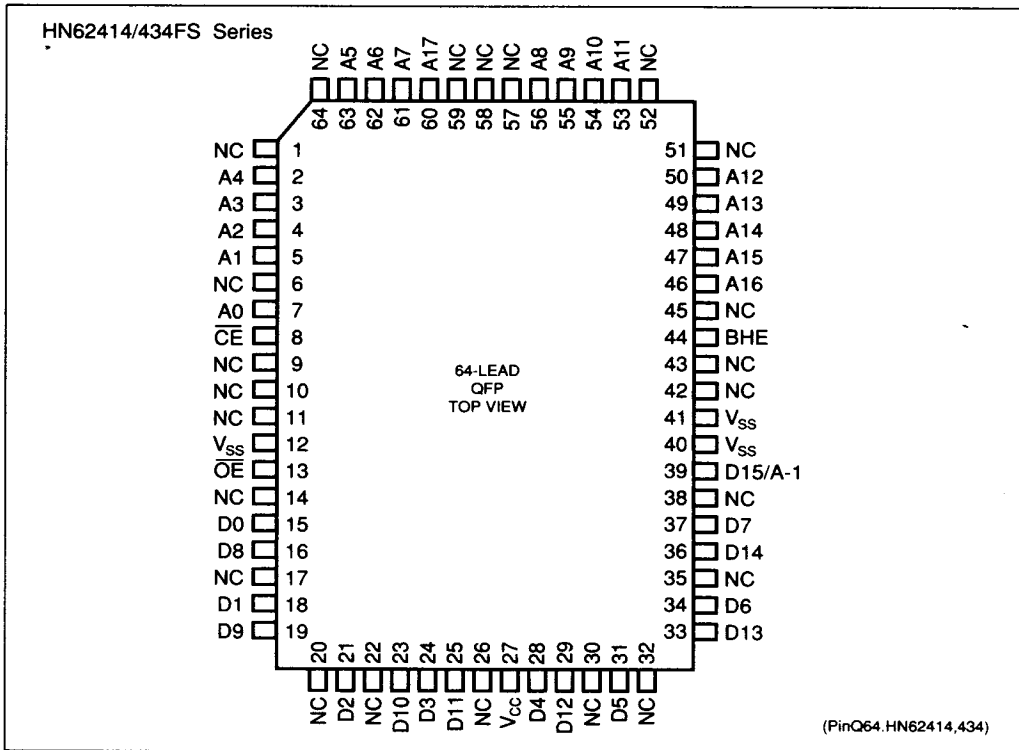

■ BLOCK DIAGRAM

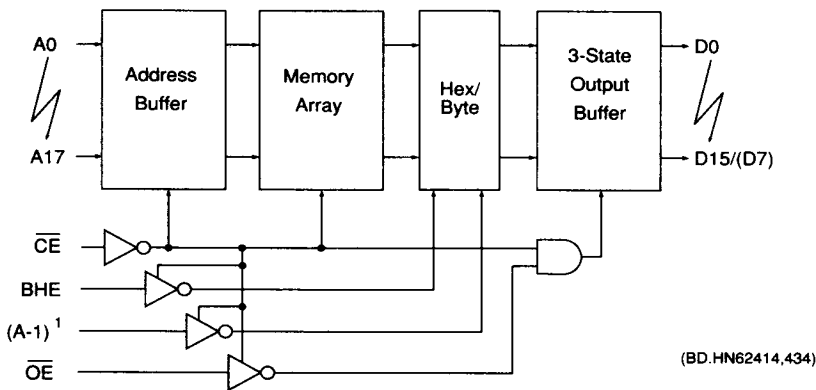

- Notes:
- * : A_{-1} is the Least Significant Address bit in Byte-Wide Mode.
 - BHE= V_{IH} : 16-bit ($D_{15} - D_0$)
 BHE= V_{IL} : 8-bit ($D_7 - D_0$)
 When BHE is low, $D_{14} - D_8$ are in high impedance states.

HITACHI

■ ABSOLUTE MAXIMUM RATINGS

Item	Symbol	Value	Unit
Supply Voltage ¹	V_{CC}	-0.3 to +7.0	V
Terminal Voltage ¹	V_T	-0.3 to $V_{CC} + 0.3$	V
Operating Temperature Range	T_{OPR}	0 to +70	°C
Storage Temperature Range	T_{STG}	-55 to +125	°C
Temperature Under Bias	T_{BIAS}	-20 to +85	°C

Notes: 1. With respect to V_{SS} .

■ CAPACITANCE

($V_{CC} = 5V \pm 10\%$, $V_{SS} = 0V$, $T_a = 25^\circ C$, $V_{IN} = 0V$, $f = 1MHz$)

Item	Symbol	Min.	Max.	Unit
Input Capacitance ¹	C_{IN}	-	15	pF
Output Capacitance ¹	C_{OUT}	-	15	pF

Notes: 1. This parameter is sampled and not 100% tested.

■ DC ELECTRICAL CHARACTERISTICS FOR READ OPERATION

($V_{CC} = 5V \pm 10\%$, $V_{SS} = 0V$, $T_a = 0$ to $70^\circ C$)

Item	Symbol	Min.	Max.	Unit	Test Condition
Input Leakage Current	I_{LI}	-	10	μA	$V_{IN} = 0$ to V_{CC}
Output Leakage Current	I_{LO}	-	10	μA	$\overline{CE} = 2.2V$, $V_{OUT} = 0$ to V_{CC}
Operating V_{CC} Current	I_{CC}	-	50	mA	$V_{CC} = 5.5V$, $I_{DOUT} = 0mA$, $t_{RC} = \text{Min.}$
Standby V_{CC} Current	I_{SB}	-	30	μA	$V_{CC} = 5.5V$, $\overline{CE} \geq V_{CC} - 0.2V$
Input Voltage	V_{IH}	2.2	$V_{CC} + 0.3$	V	
	V_{IL}	-0.3	0.8	V	
Output Voltage	V_{OH}	2.4	-	V	$I_{OH} = -205 \mu A$
	V_{OL}	-	0.4	V	$I_{OL} = 1.6 mA$

■ AC ELECTRICAL CHARACTERISTICS FOR READ OPERATION
 $(V_{CC} = 5V \pm 10\%, V_{SS} = 0V, T_a = 0 \text{ to } 70^\circ\text{C})$
Test Conditions

- Input pulse levels: 0.8 V / 2.4 V
- Input rise and fall times: ≤ 10 ns
- Output load: 1 TTL Gate + CL = 100 pF (Including jig capacitance)
- Input/Output Timing Reference level: 1.5 V

Item	Symbol	HN62434-15		HN62414-17		HN62414-20		Unit
		Min.	Max.	Min.	Max.	Min.	Max.	
Read Cycle Time	t_{RC}	150	-	170	-	200	-	ns
Address Access Time	t_{AA}	-	150	-	170	-	200	ns
\overline{CE} Access Time	t_{ACE}	-	150	-	170	-	200	ns
\overline{OE} Access Time	t_{OE}	-	70	-	70	-	100	ns
BHE Access Time	t_{BHE}	-	150	-	170	-	200	ns
Output Hold Time from Address Change	t_{DHA}	0	-	0	-	0	-	ns
Output Hold Time from \overline{CE}	t_{DHC}	0	-	0	-	0	-	ns
Output Hold Time from \overline{OE}	t_{DHO}	0	-	0	-	0	-	ns
Output Hold Time from BHE	t_{DHB}	0	-	0	-	0	-	ns
\overline{CE} to Output in High Z ¹	t_{CHZ}	-	70	-	70	-	70	ns
\overline{OE} to Output in High Z ¹	t_{OHZ}	-	70	-	70	-	70	ns
BHE to Output in High Z ¹	t_{BHZ}	-	70	-	70	-	70	ns
\overline{CE} to Output in Low Z	t_{CLZ}	10	-	10	-	10	-	ns
\overline{OE} to Output in Low Z	t_{OLZ}	10	-	10	-	10	-	ns
BHE to Output in Low Z	t_{BLZ}	10	-	10	-	10	-	ns

Note: 1. t_{CHZ} , t_{OHZ} , and t_{BHZ} are defined as the time at which the output becomes an open circuit and are not referenced to output voltage levels.

HITACHI

■ READ TIMING WAVEFORM

Word Mode (BHE = V_{IH}) or Byte Mode (BHE = V_{IL})

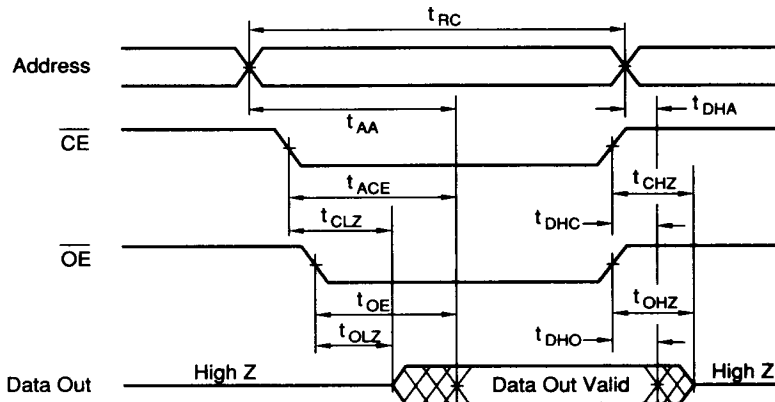

(TD.R.HN62414,434)

- Note:
1. t_{DHA} , t_{DHC} , t_{DHO} are determined by the faster time.
 2. t_{AA} , t_{ACE} , t_{OE} are determined by the slower time.
 3. t_{CLZ} , t_{OLZ} are determined by the slower time.

Word Mode/Byte Mode Switch

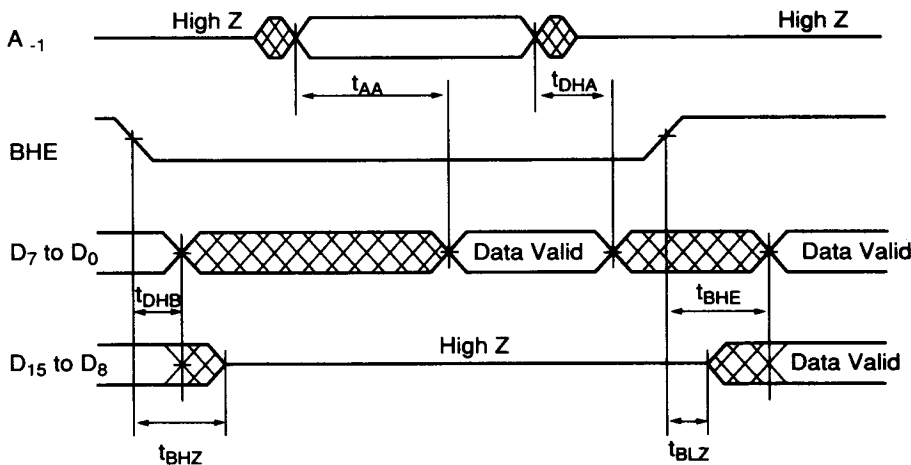

(TD.R1.HN62414,434)

- Note:
1. \overline{CE} and \overline{OE} are enabled, A_{17} to A_0 are valid.
 2. D_{15}/A_{-1} pin is in the output state when BHE is high, \overline{CE} and \overline{OE} are enabled. Therefore, the input signals of opposite phase to the output must not be applied to them.