

CB-31 (SL SERVO)

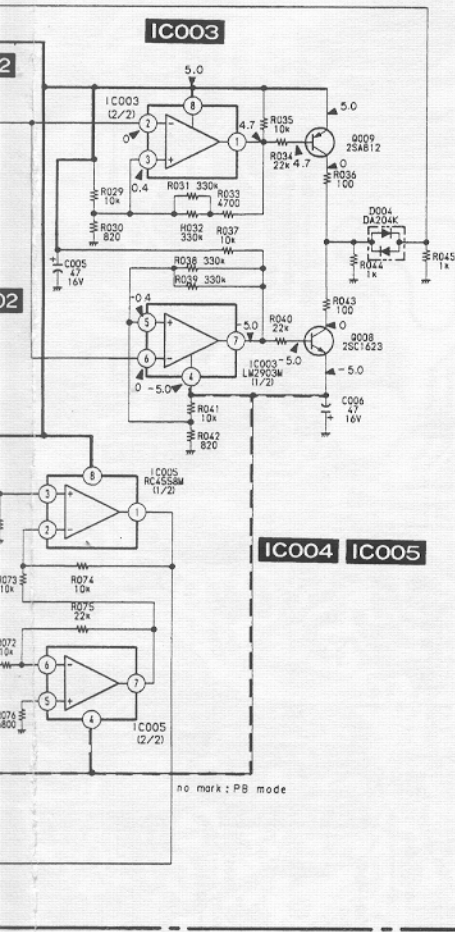

• Signal path

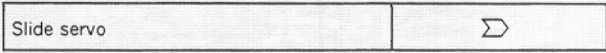

- D001 A-4
- D002 B-3
- D003 A-3
- D004 B-2
- D005 C-4
- D006 B-4

- IC001 A-3
- IC002 A-2
- IC003 A-1
- IC004 C-4
- IC005 C-3

- Q001 A-4
- Q002 B-4
- Q003 A-3
- Q004 B-3
- Q005 A-3
- Q006 A-4
- Q007 A-3
- Q008 A-2
- Q009 A-1
- Q010 A-4

1 2 3 4

MB-40 BOARD (S/S)

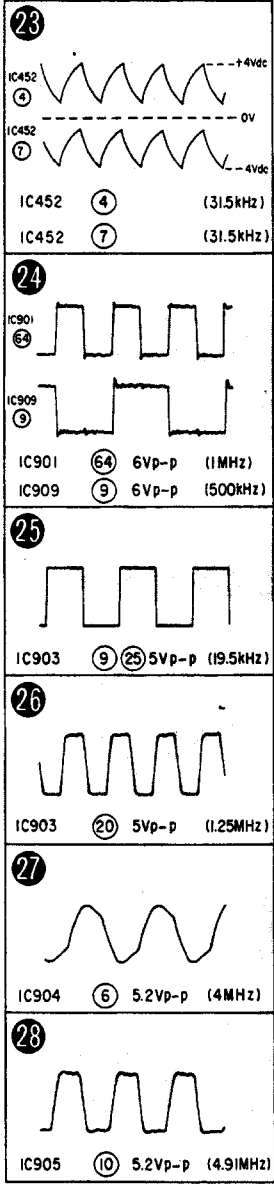

• Signal path

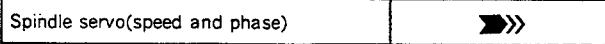

A
B
C
D
E
F
G
H
I
J

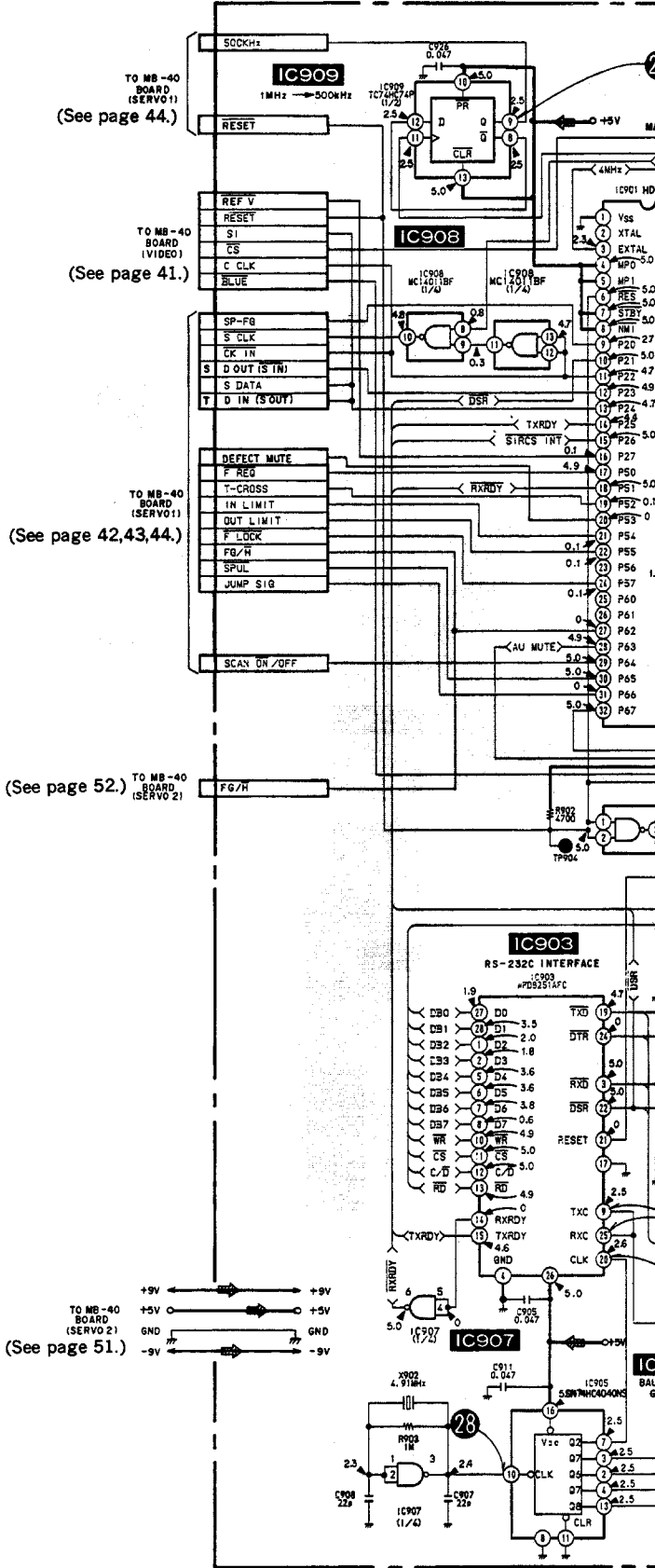

MB-40 (1/4) (SERVO2)

(See page 44.)
 TO MB-40 BOARD (SERVO1)
 TO MB-40 BOARD (VIDEO) 39,41.)
 TO MB-40 BOARD (SERVO1) (See page 43.)
 TO MB-40 BOARD (VIDEO) (See page 41.)
 TO MB-40 BOARD (SERVO1) (See page 44.)
 TO MB-40 BOARD (SERVO2) (See page 52.)
 TO MB-40 BOARD (SERVO1) (See page 44.)
 TO MB-40 BOARD (SERVO2) (See page 39.)
 TO MB-40 BOARD (SERVO2) (See page 52.)

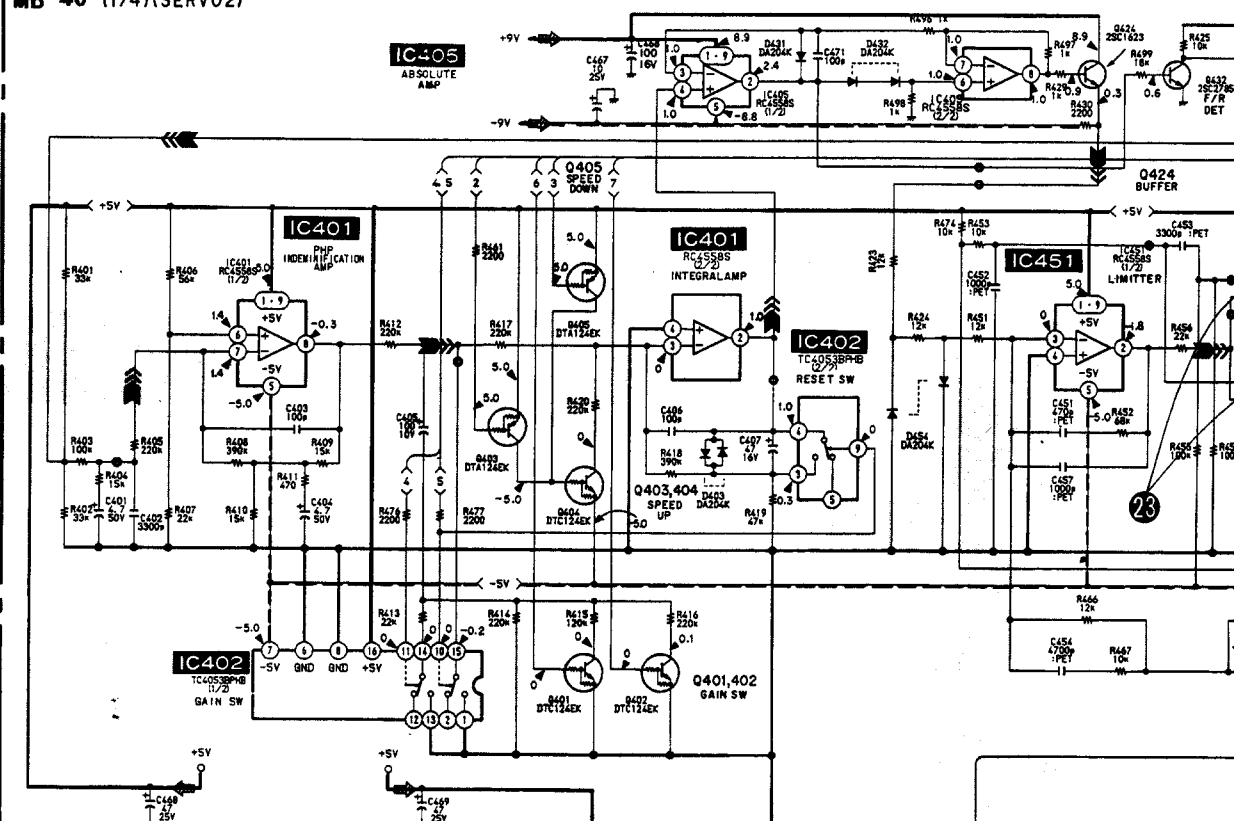

(See page 44.)
 TO MB-40 BOARD (SERVO1)

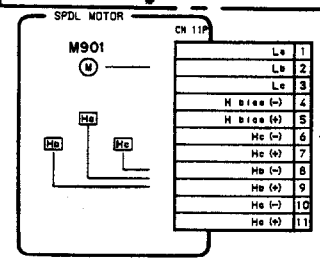

J901 REMOTE

(See page 47.)
 TO CB-31 BOARD CNO04

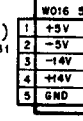

(See page 60.)
 TO DC-40 BOARD CNO03

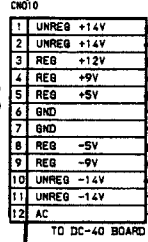

TO MB-40 BOARD (SERVO1) (See page 42.)
 TO MB-40 BOARD (SYSTEM CONTROL) (See page 49.)

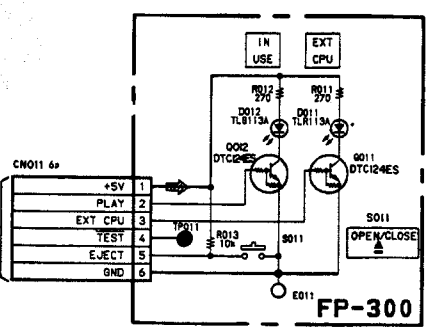

(See page 41.)

(See page 59.)

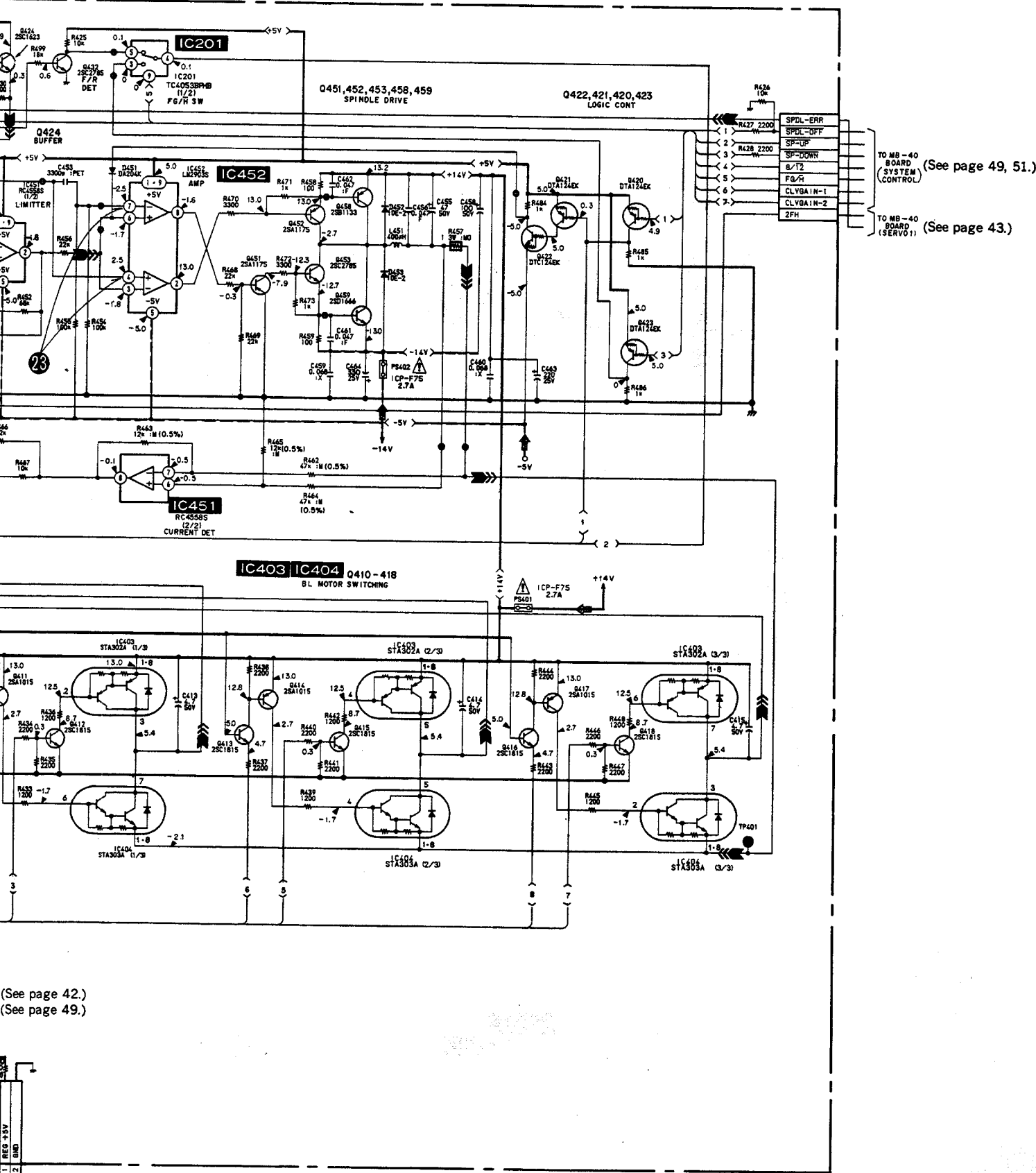

(See page 42.)
(See page 49.)

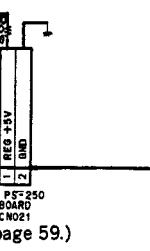

D001	I-6	Q016	I-3
D002	I-4	Q017	I-2
D005	H-2	Q018	I-2
D101	H-5	Q019	I-2
D102	I-4	Q020	I-1
D103	H-3	Q021	I-1
D121	G-6	Q022	J-4
D201	C-9	Q023	H-1
D202	C-9	Q024	G-1
D204	C-9	Q025	G-1
D206	E-6	Q101	G-3
D300	D-5	Q102	G-2
D301	D-5	Q103	G-2
D302	D-8	Q104	G-3
D307	D-5	Q105	H-5
D310	D-4	Q121	G-6
D403	A-9	Q122	G-6
D431	B-10	Q201	E-6
D432	B-10	Q202	G-5
D451	D-10	Q203	F-8
D452	D-13	Q204	E-8
D453	D-12	Q205	E-8
D454	C-10	Q206	F-3
		Q303	D-8
		Q304	D-7
		Q305	D-8
IC001	I-7	Q306	D-5
IC002	I-5	Q307	D-5
IC003	J-5	Q308	E-4
IC004	I-2	Q310	C-6
IC005	H-2	Q311	C-6
IC006	G-2	Q312	C-7
IC101	G-4	Q313	C-8
IC102	G-3	Q314	C-8
IC103	H-6	Q401	B-9
IC104	H-4	Q402	B-9
IC105	I-4	Q403	A-9
IC106	H-3	Q404	A-10
IC107	I-3	Q405	A-9
IC121	G-7	Q410	A-11
IC201	C-9	Q411	B-11
IC202	G-5	Q412	B-12
IC203	E-8	Q413	A-11
IC205	E-7	Q414	B-11
IC206	F-8	Q415	B-12
IC207	E-8	Q416	A-11
IC208	C-9	Q417	B-11
IC209	D-9	Q418	B-12
IC301	D-2	Q420	D-10
IC302	E-3	Q421	D-10
IC303	B-2	Q422	D-10
IC304	A-1	Q423	B-9
IC305	C-4	Q424	C-10
IC306	D-5	Q432	B-10
IC307	A-3	Q451	D-11
IC308	C-4	Q452	D-11
IC309	D-7	Q453	D-12
IC310	E-2	Q458	D-12
IC312	C-8	Q459	D-12
IC313	E-5		
IC401	A-10		
IC402	A-9		
IC403	B-12		
IC404	B-11		
IC405	B-10		
IC451	C-10		
IC452	D-10		
IC453	A-12		
IC901	H-9		
IC902	G-12		
IC903	J-11		
IC904	H-13		
IC905	I-8		
IC906	J-10		
IC907	I-9		
IC908	G-11		
IC909	G-8		
IC910	I-13		
Q001	B-7		
Q002	A-7		
Q003	A-7		
Q004	A-7		
Q005	I-6		
Q006	I-5		
Q007	I-7		
Q008	I-6		
Q009	J-6		
Q010	J-4		
Q011	I-3		
Q012	J-4		
Q013	J-4		
Q014	J-3		
Q015	I-3		

MB-40 BOARD

