

NM27P512

524,288-Bit (64K x 8) Processor Oriented CMOS EPROM

General Description

The NM27P512 is a 512K Processor Oriented EPROM configured as 64k x 8. It's designed to simplify microprocessor interfacing while remaining compatible with standard EPROMs. It can reduce both wait states and glue logic when the specification improvements are taken advantage of in the system design. The NM27P512 is implemented in National's advanced CMOS EPROM process to provide excellent reliability and access times as fast as 120 ns.

The interface improvements address two areas to eliminate the need for additional devices to adapt the EPROM to the microprocessor and to eliminate wait states at the termination of the access cycle. Even with these improvements, the NM27P512 remains compatible with industry standard JEDEC pinout EPROMs. The maximum specification for output turn-off time has been reduced, eliminating the need for wait states at the end of a read cycle. Also, the minimum specification for output hold time has been increased, eliminating the need for external circuitry to hold the data.

Features

- Fast output turn off to eliminate wait states
- Extended data hold time for microprocessor compatibility
- High performance CMOS
 - 120 ns access time
- JEDEC standard pin configuration
- Manufacturer's identification code

Block Diagram

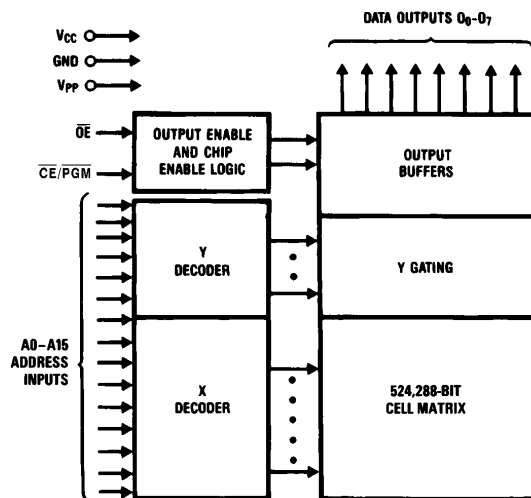

TL/D/11365-1

TRI-STATE® is a registered trademark of National Semiconductor Corporation.
NSC800™ is a trademark of National Semiconductor Corporation.

Connection Diagrams

27C080	27C040	27C020	27C010	27C256
A19	XX/V _{PP}	XX/V _{PP}	XX/V _{PP}	
A16	A16	A16	A16	V _{PP}
A15	A15	A15	A15	A12
A12	A12	A12	A12	A7
A7	A7	A7	A7	A6
A6	A6	A6	A6	A5
A5	A5	A5	A5	A4
A4	A4	A4	A4	A3
A3	A3	A3	A3	A2
A2	A2	A2	A2	A1
A1	A1	A1	A1	A0
A0	A0	A0	A0	O0
O0	O0	O0	O0	O1
O1	O1	O1	O1	O2
O2	O2	O2	O2	
GND	GND	GND	GND	

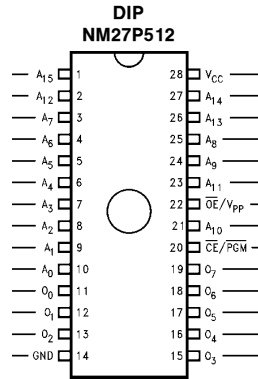

27C256	27C010	27C020	27C040	27C080
	V _{CC}	V _{CC}	V _{CC}	V _{CC}
	XX/PGM	XX/PGM	A18	A18
V _{CC}	XX	A17	A17	A17
A14	A14	A14	A14	A14
A13	A13	A13	A13	A13
A8	A8	A8	A8	A8
A9	A9	A9	A9	A9
A11	A11	A11	A11	A11
OE	OE	OE	OE	OE/V _{PP}
A10	A10	A10	A10	A10
CE/PGM	CE	CE	CE/PGM	CE/PGM
O7	O7	O7	O7	O7
O6	O6	O6	O6	O6
O5	O5	O5	O5	O5
O4	O4	O4	O4	O4
O3	O3	O3	O3	O3

TL/D/11365-2

Note: Compatible EPROM pin configurations are shown in the blocks adjacent to the NM27P512 pins.

Commercial Temp Range (0°C to +70°C)

Parameter/Order Number	Access Time (ns)*
NM27P512 Q, N, V 120	120
NM27P512 Q, N, V 150	150
NM27P512 Q, N, V 200	200

Military Temp Range (-55°C to +125°C)

Parameter/Order Number	Access Time (ns)*
NM27P512 QM 200	200

Extended Temp Range (-40°C to +85°C)

Parameter/Order Number	Access Time (ns)*
NM27P512 QE, NE, VE 120	120
NM27P512 QE, NE, VE 150	150
NM27P512 QE, NE, VE 200	200

Note: Surface mount PLCC package available for commercial and extended temperature ranges only.

*All versions are guaranteed to function for slower speeds.

Package Types: NM27P512 Q, N, V XXX
 Q = Quartz-Windowed Ceramic DIP Package
 N = Plastic OTP DIP Package
 V = PLCC Package

- All packages conform to the JEDEC standard.

Pin Names

A0–A15	Addresses
\overline{CE}	Chip Enable
\overline{OE}	Output Enable
O0–O7	Outputs
PGM	Program
XX	Don't Care (During Read)

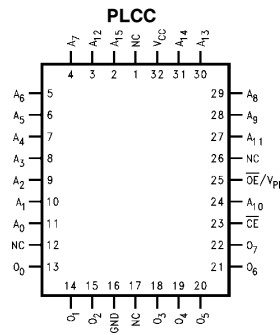

TL/D/11365-3

Absolute Maximum Ratings (Note 1)

If Military/Aerospace specified devices are required, please contact the National Semiconductor Sales Office/Distributors for availability and specifications.

Storage Temperature	-65°C to +150°C
All Input Voltages Except A9 with Respect to Ground	-0.6V to +7V
V _{PP} and A9 with Respect to Ground	-0.7V to +14V

V _{CC} Supply Voltage with Respect to Ground	-0.6V to +7V
ESD Protection (MIL Std. 883, Method 3015.2)	>2000V
All Output Voltages with Respect to Ground	V _{CC} + 1.0V to GND -0.6V

Operating Range

Range	Temperature	V _{CC}	Tolerance
Comm'l	0°C to +70°C	+5V	±10%
Industrial	-40°C to +85°C	+5V	±10%
Military	-55°C to +125°C	+5V	±10%

Read Operation

DC Electrical Characteristics

Symbol	Parameter	Test Conditions	Min	Max	Units
V _{IL}	Input Low Level		-0.5	08	V
V _{IH}	Input High Level		2.0	V _{CC} + 1	V
V _{OL}	Output Low Voltage	I _{OL} = 2.1 mA		0.4	V
V _{OH}	Output High Voltage	I _{OH} = -2.5 mA	3.5		V
I _{SB1} (10)	V _{CC} Standby Current (CMOS)	$\overline{CE} = V_{CC} \pm 0.3V$		100	μA
I _{SB2}	V _{CC} Standby Current	$\overline{CE} = V_{IH}$		1	mA
I _{CC}	V _{CC} Active Current	$\overline{CE} = \overline{OE} = V_{IL}$, I/O = 0 mA	f = 5 MHz	40	mA
I _{PP}	V _{PP} Supply Current	V _{PP} = V _{CC}		10	μA
V _{PP}	V _{PP} Read Voltage		V _{CC} - 0.7	V _{CC}	V
I _{LI}	Input Load Current	V _{IN} = 5.5V or GND	-1	1	μA
I _{LO}	Output Leakage Current	V _{OUT} = 5.5V or GND	-10	10	μA

AC Electrical Characteristics

Symbol	Parameter	120		150		200		Units
		Min	Max	Min	Max	Min	Max	
t _{ACC}	Address to Output Delay		120		150		200	ns
t _{CE}	\overline{CE} to Output Delay		120		150		200	
t _{OE}	\overline{OE} to Output Delay		50		50		50	
t _{DF} (2)	Output Disable to Output Float		25		25		25	
t _{CF} (2)	Chip Disable to Output Float		30		30		30	
t _{OH} (2)	Output Hold from Addresses, \overline{CE} or \overline{OE} , Whichever Occurred First	7		7		7		

Capacitance $T_A = +25^\circ\text{C}$, $f = 1\text{ MHz}$ (Note 2)

Symbol	Parameter	Conditions	Typ	Max	Units
C_{IN1}	Input Capacitance except \overline{OE}/V_{PP}	$V_{IN} = 0V$	6	12	pF
C_{OUT}	Output Capacitance	$V_{OUT} = 0V$	9	12	pF
C_{IN2}	\overline{OE}/V_{PP} Input Capacitance	$V_{IN} = 0V$	20	25	pF

AC Test Conditions

Output Load	1 TTL Gate and $C_L = 100\text{ pF}$ (Note 8)	Timing Measurement Reference Level (Note 9)	
Input Rise and Fall Times	$\leq 5\text{ ns}$	Inputs	0.8V and 2V
Input Pulse Levels	0.45V to 2.4V	Outputs	0.8V and 2V

AC Waveforms (Notes 6, 7)

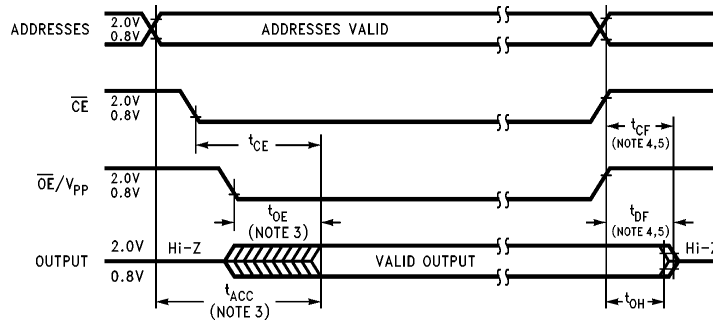

Note 1: Stresses above those listed under "Absolute Maximum Ratings" may cause permanent damage to the device. This is a stress rating only and functional operation of the device at these or any other conditions above those indicated in the operational sections of this specification is not implied. Exposure to absolute maximum rating conditions for extended periods may affect device reliability.

Note 2: This parameter is only sampled and is not 100% tested.

Note 3: \overline{OE} may be delayed up to $t_{ACC} - t_{OE}$ after the falling edge of \overline{CE} without impacting t_{ACC} .

Note 4: The t_{DF} and t_{CF} compare level is determined as follows:

- High to TRI-STATE, the measured V_{OH1} (DC) - 0.10V;
- Low to TRI-STATE, the measured V_{OL1} (DC) + 0.10V.

Note 5: TRI-STATE may be attained using \overline{OE} or \overline{CE} .

Note 6: The power switching characteristics of EPROMs require careful device decoupling. It is recommended that at least a 0.1 μF ceramic capacitor be used on every device between V_{CC} and GND.

Note 7: The outputs must be restricted to $V_{CC} + 1.0V$ to avoid latch-up and device damage.

Note 8: 1 TTL Gate: $I_{OL} = 1.6\text{ mA}$, $I_{OH} = -400\text{ }\mu\text{A}$.
 C_L : 100 pF includes fixture capacitance.

Note 9: Inputs and outputs can undershoot to $-2.0V$ for 20 ns Max.

Note 10: CMOS inputs; $V_{IL} = GND \pm 0.3V$, $V_{IH} = V_{CC} \pm 0.3V$.

Programming Characteristics (Notes 1 and 2)

Symbol	Parameter	Conditions	Min	Typ	Max	Units
t_{AS}	Address Setup Time		1			μs
t_{OES}	\overline{OE} Setup Time		1			μs
t_{DS}	Data Setup Time		1			μs
t_{VCS}	V_{CC} Setup Time		1			μs
t_{AH}	Address Hold Time		0			μs
t_{DH}	Data Hold Time		1			μs
t_{CF}	Chip Enable to Output Float Delay	$\overline{OE} = V_{IL}$	0		60	ns
t_{PW}	Program Pulse Width		95	100	105	μs
t_{OEH}	\overline{OE} Hold Time		1			μs
t_{DV}	Data Valid from \overline{CE}	$\overline{OE} = V_{IL}$			250	ns
t_{PRT}	\overline{OE} Pulse Rise Time during Programming		50			ns
t_{VR}	V_{PP} Recovery Time		1			μs
I_{PP}	V_{PP} Supply Current during Programming Pulse	$\overline{CE} = V_{IL}$ $\overline{OE} = V_{PP}$			30	mA
I_{CC}	V_{CC} Supply Current				50	mA
T_R	Temperature Ambient		20	25	30	$^{\circ}\text{C}$
V_{CC}	Power Supply Voltage		6	6.25	6.5	V
V_{PP}	Programming Supply Voltage		12.5	12.75	13	V
t_{FR}	Input Rise, Fall Time		5			ns
V_{IL}	Input Low Voltage			0	0.45	V
V_{IH}	Input High Voltage		2.4	4		V
t_{IN}	Input Timing Reference Voltage		0.8		2	V
t_{OUT}	Output Timing Reference Voltage		0.8		2	V

Programming Waveforms

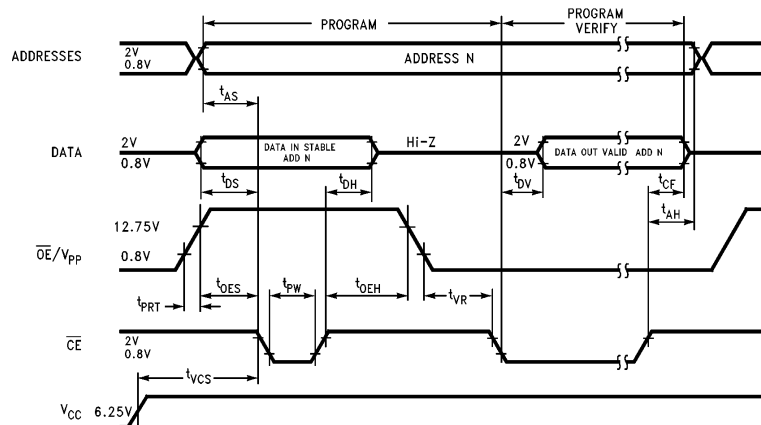

TL/D/11365-5

Note 1: National's standard product warranty applies to devices programmed to specifications described herein.

Note 2: V_{CC} must be applied simultaneously or before V_{PP} and removed simultaneously or after V_{PP} . The EPROM must not be inserted into or removed from a board with voltage applied to V_{PP} or V_{CC} .

Note 3: The maximum absolute allowable voltage which may be applied to the V_{PP} pin during programming is 14V. Care must be taken when switching the V_{PP} supply to prevent any overshoot from exceeding this 14V maximum specification. At least a 0.1 μF capacitor is required across V_{CC} to GND to suppress spurious voltage transients which may damage the device.

Note 4: Programming and program verify are tested with the fast Program Algorithm at typical power supply voltages and timings.

Fast Programming Algorithm Flow Chart

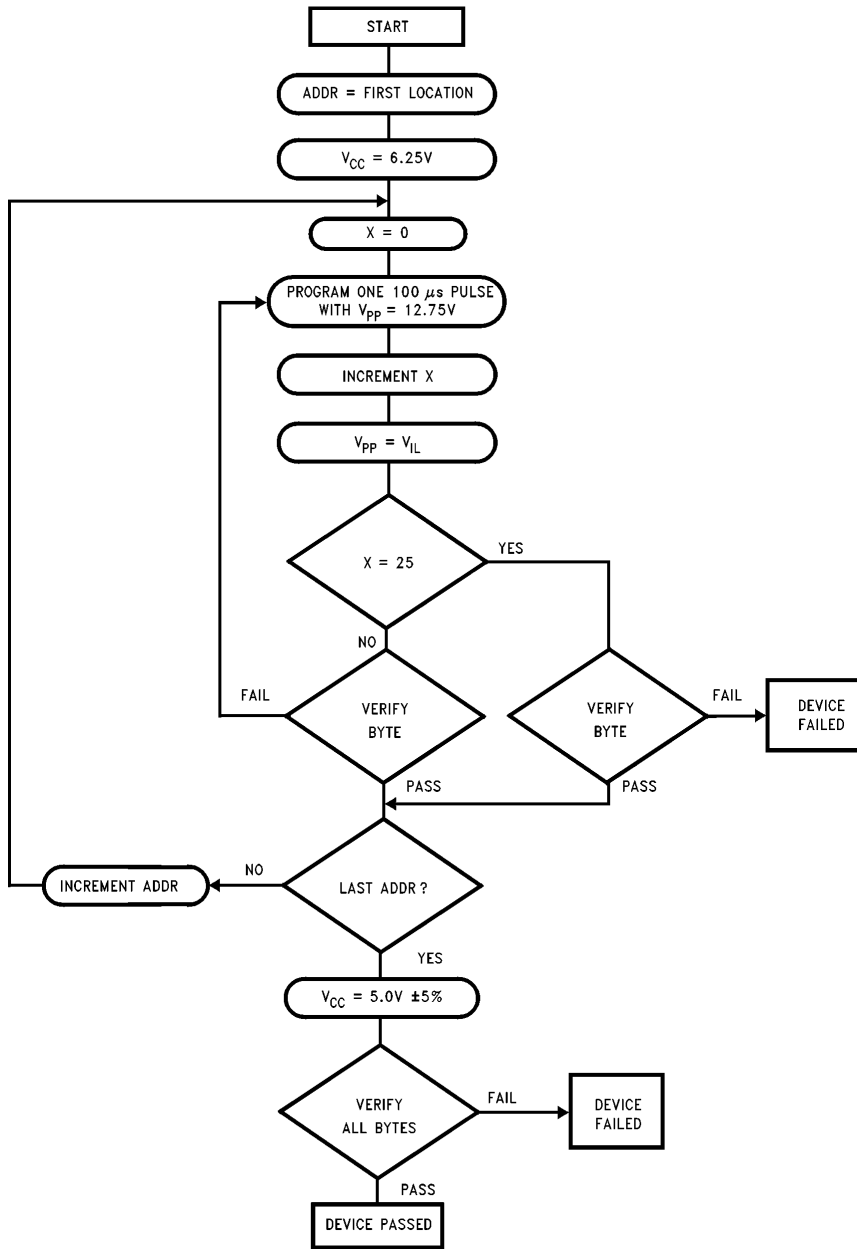

FIGURE 1

TL/D/11365-6

Functional Description

DEVICE OPERATION

The six modes of operation of the EPROM are listed in Table I. It should be noted that all inputs for the six modes are at TTL levels. The power supplies required are V_{CC} and OE/V_{PP} . The OE/V_{PP} power supply must be at 12.75V during the three programming modes, and must be at 5V in the other three modes. The V_{CC} power supply must be at 6.25V during the three programming modes, and at 5V in the other three modes.

Read Mode

The EPROM has two control functions, both of which must be logically active in order to obtain data at the outputs. Chip Enable (CE/PGM) is the power control and should be used for device selection. Output Enable (OE/V_{PP}) is the output control and should be used to gate data to the output pins, independent of device selection. Assuming that addresses are stable, address access time (t_{ACC}) is equal to the delay from CE to output (t_{CE}). Data is available at the outputs t_{OE} after the falling edge of OE, assuming that CE has been low and addresses have been stable for at least $t_{ACC}-t_{OE}$.

Standby Mode

The EPROM has a standby mode which reduces the active power dissipation by over 99%, from 385 mW to 0.55 mW. The EPROM is placed in the standby mode by applying a CMOS high signal to the CE/PGM input. When in standby mode, the outputs are in a high impedance state, independent of the OE input.

Output Disable

The EPROM is placed in output disable by applying a TTL high signal to the OE input. When in output disable all circuitry is enabled, except the outputs are in a high impedance state (TRI-STATE).

Output OR-Typing

Because the EPROM is usually used in larger memory arrays, National has provided a 2-line control function that accommodates this use of multiple memory connections. The 2-line control function allows for:

- a) the lowest possible memory power dissipation, and
- b) complete assurance that output bus contention will not occur.

To most efficiently use these two control lines, it is recommended that CE/PGM be decoded and used as the primary device selecting function, while OE/V_{PP} be made a common connection to all devices in the array and connected to the READ line from the system control bus.

This assures that all deselected memory devices are in their low power standby modes and that the output pins are active only when data is desired from a particular memory device.

Programming

CAUTION: Exceeding 14V on pin 22 (OE/V_{PP}) will damage the EPROM.

Initially, and after each erasure, all bits of the EPROM are in the "1's" state. Data is introduced by selectively programming "0's" into the desired bit locations. Although only "0's" will be programmed, both "1's" and "0's" can be presented in the data word. The only way to change a "0" to a "1" is by ultraviolet light erasure.

The EPROM is in the programming mode when the OE/V_{PP} is at 12.75V. It is required that at least a 0.1 μ F capacitor be placed across V_{CC} to ground to suppress spurious voltage transients which may damage the device. The data to be programmed is applied 8 bits in parallel to the data output pins. The levels required for the address and data inputs are TTL.

When the address and data are stable, an active low, TTL program pulse is applied to the CE/PGM input. A program pulse must be applied at each address location to be programmed.

The EPROM is programmed with the Fast Programming Algorithm shown in *Figure 1*. Each Address is programmed with a series of 100 μ s pulses until it verifies good, up to a maximum of 25 pulses. Most memory cells will program with a single 100 μ s pulse.

The EPROM must not be programmed with a DC signal applied to the CE/PGM input.

Programming multiple EPROM in parallel with the same data can be easily accomplished due to the simplicity of the programming requirements. Like inputs of the parallel EPROM may be connected together when they are programmed with the same data. A low level TTL pulse applied to the CE/PGM input programs the paralleled EPROM.

Program Inhibit

Programming multiple EPROMs in parallel with different data is also easily accomplished. Except for CE/PGM all like inputs (including OE/V_{PP}) of the parallel EPROMs may be common. A TTL low level program pulse applied to an EPROM's CE/PGM input with OE/V_{PP} at 12.75V will program that EPROM. A TTL high level CE/PGM input inhibits the other EPROMs from being programmed.

Functional Description (Continued)

Program Verify

A verify should be performed on the programmed bits to determine whether they were correctly programmed. The verify is accomplished with OE/V_{PP} and CE at V_{IL}. Data should be verified T_{DV} after the falling edge of CE.

AFTER PROGRAMMING

Opaque labels should be placed over the EPROM window to prevent unintentional erasure. Covering the window will also prevent temporary functional failure due to the generation of photo currents.

MANUFACTURER'S IDENTIFICATION CODE

The EPROM has a manufacturer's identification code to aid in programming. When the device is inserted in an EPROM programmer socket, the programmer reads the code and then automatically calls up the specific programming algorithm for the part. This automatic programming control is only possible with programmers which have the capability of reading the code.

The Manufacturer's Identification code, shown in Table II, specifically identifies the manufacturer and device type. The code for NM27P512 is "8F85", where "8F" designates that it is made by National Semiconductor, and "85" designates a 512K part.

The code is accessed by applying 12V ±0.5V to address pin A9. Addresses A1–A8, A10–A16, and all control pins are held at V_{IL}. Address pin A0 is held at V_{IL} for the manufacturer's code, and held at V_{IH} for the device code. The code is read on the eight data pins, O₀–O₇. Proper code access is only guaranteed at 25°C ±5°C.

ERASURE CHARACTERISTICS

The erasure characteristics of the device are such that erasure begins to occur when exposed to light with wavelengths shorter than approximately 4000 Angstroms (Å). It should be noted that sunlight and certain types of fluorescent lamps have wavelengths in the 3000Å–4000Å range.

The recommended erasure procedure for the EPROM is exposure to short wave ultraviolet light which has a wave-

length of 2537Å. The integrated dose (i.e., UV intensity × exposure time) for erasure should be minimum of 15W-sec/cm².

The EPROM should be placed within 1 inch of the lamp tubes during erasure. Some lamps have a filter on their tubes which should be removed before erasure. Table III shows the minimum EPROM erasure time for various light intensities.

An erasure system should be calibrated periodically. The distance from lamp to device should be maintained at one inch. The erasure time increase as the square of the distance from the lamp (if distance is doubled the erasure time increases by factor of 4). Lamps lose intensity as they age. When a lamp is changed, the distance has changed, or the lamp has aged, the system should be checked to make certain full erasure is occurring. Incomplete erasure will cause symptoms that can be misleading. Programmers, components, and even system designs have been erroneously suspected when incomplete erasure was the problem.

SYSTEM CONSIDERATION

The power switching characteristics of EPROMs require careful decoupling of the devices. The supply current, I_{CC}, has three segments that are of interest to the system designer: the standby current level, the active current level, and the transient current peaks that are produced by voltage transitions on input pins. The magnitude of these transient current peaks is dependent of the output capacitance loading of the device. The associated V_{CC} transient voltage peaks can be suppressed by properly selected decoupling capacitors. It is recommended that at least a 0.1 μF ceramic capacitor be used on every device between V_{CC} and GND. This should be a high frequency capacitor of low inherent inductance. In addition, at least a 4.7 μF bulk electrolytic capacitor should be used between V_{CC} and GND for each eight devices. The bulk capacitor should be located near where the power supply is connected to the array. The purpose of the bulk capacitor is to overcome the voltage drop caused by the inductive effects of the PC board traces.

Mode Selection

The modes of operation of the NM27P512 are listed in Table I. A single 5V power supply is required in the read mode. All inputs are TTL levels excepts for V_{PP} and A9 for device signature.

TABLE I. Mode Selection

Mode	Pins \overline{CE}/PGM	\overline{OE}/V_{PP}	V_{CC}	Outputs
Read	V_{IL}	V_{IL}	5.0V	D_{OUT}
Output Disable	X (Note 1)	V_{IH}	5.0V	High Z
Standby	V_{IH}	X	5.0V	High Z
Programming	V_{IL}	12.75V	6.25V	D_{IN}
Program Verify	V_{IL}	V_{IL}	6.25V	D_{OUT}
Program Inhibit	V_{IH}	12.75V	6.25V	High Z

Note 1: X can be V_{IL} or V_{IH} .

TABLE II. Manufacturer's Identification Code

Pins	A0 (10)	A9 (24)	07 (19)	06 (18)	05 (17)	04 (16)	03 (15)	02 (13)	01 (12)	00 (11)	Hex Data
Manufacturer Code	V_{IL}	12V	1	0	0	0	1	1	1	1	8F
Device Code	V_{IH}	12V	1	0	0	0	0	1	0	1	85



Physical Dimensions inches (millimeters)

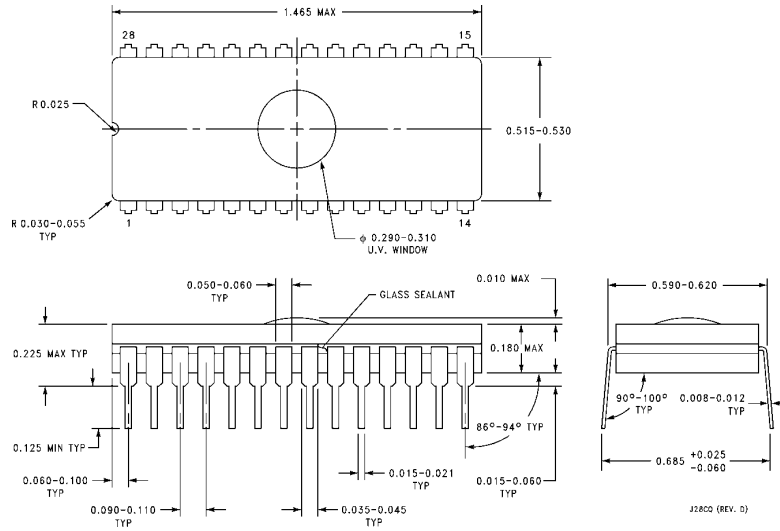

UV Window Cavity Dual-In-Line Cerdip Package (Q)
Order Number NM27P512Q
NS Package Number J28CQ

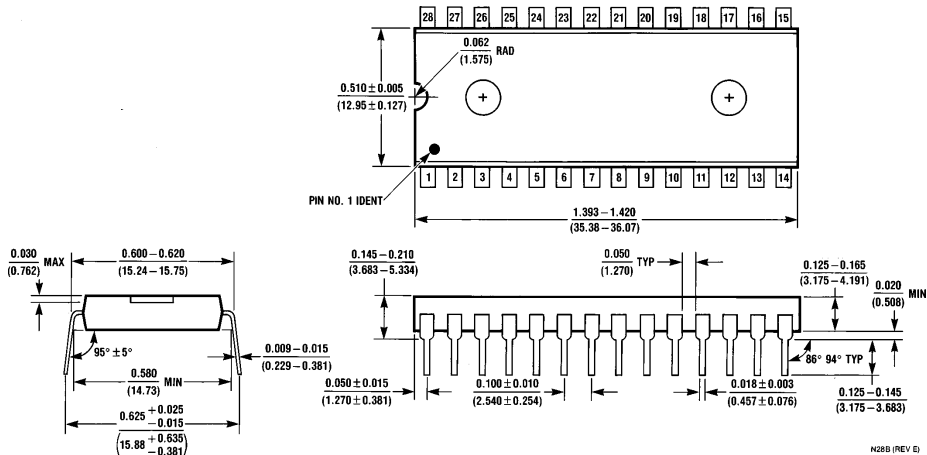

28-Lead Plastic One-Time-Programmable Dual-In-Line
Order Number NM27P512N
NS Package Number N28B

Physical Dimensions inches (millimeters) (Continued)

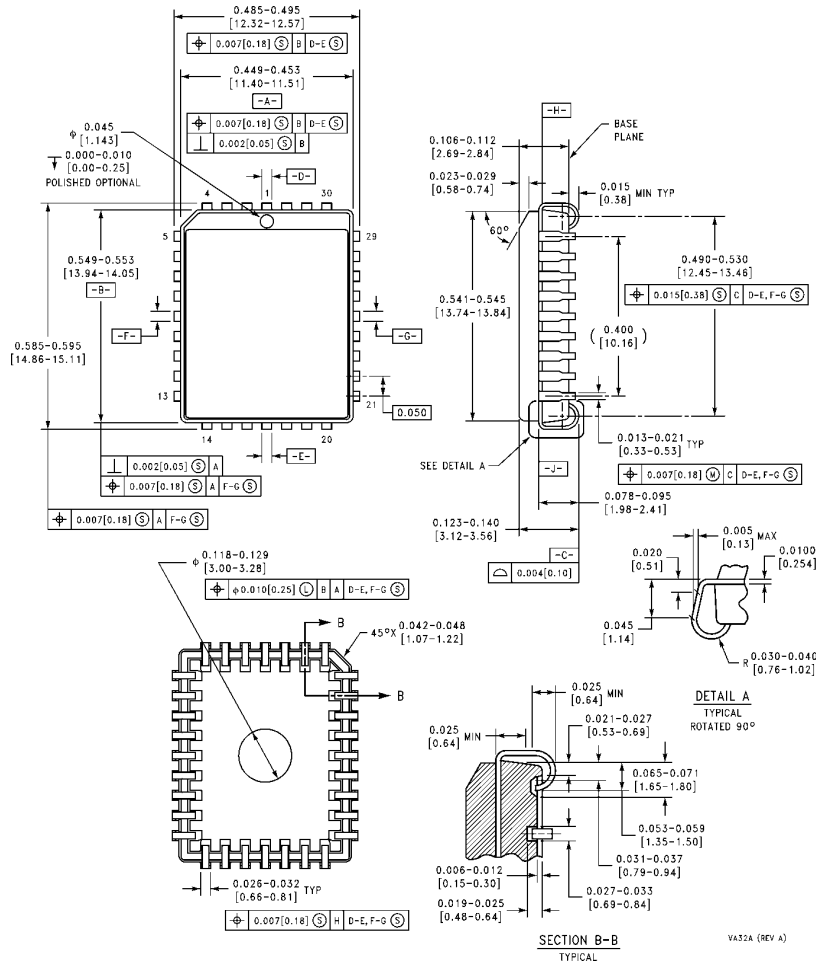

32-Lead Plastic Leaded Chip Carrier (PLCC)
Order Number NM27P512V
NS Package Number VA32A

LIFE SUPPORT POLICY

NATIONAL'S PRODUCTS ARE NOT AUTHORIZED FOR USE AS CRITICAL COMPONENTS IN LIFE SUPPORT DEVICES OR SYSTEMS WITHOUT THE EXPRESS WRITTEN APPROVAL OF THE PRESIDENT OF NATIONAL SEMICONDUCTOR CORPORATION. As used herein:

1. Life support devices or systems are devices or systems which, (a) are intended for surgical implant into the body, or (b) support or sustain life, and whose failure to perform, when properly used in accordance with instructions for use provided in the labeling, can be reasonably expected to result in a significant injury to the user.
2. A critical component is any component of a life support device or system whose failure to perform can be reasonably expected to cause the failure of the life support device or system, or to affect its safety or effectiveness.



National Semiconductor Corporation
 1111 West Bardin Road
 Arlington, TX 76017
 Tel: 1(800) 272-9959
 Fax: 1(800) 737-7018

National Semiconductor Europe
 Fax: (+49) 0-180-530 85 86
 Email: cnjwge@tevm2.nsc.com
 Deutsch Tel: (+49) 0-180-530 85 85
 English Tel: (+49) 0-180-532 78 32
 Français Tel: (+49) 0-180-532 93 58
 Italiano Tel: (+49) 0-180-534 16 80

National Semiconductor Hong Kong Ltd.
 19th Floor, Straight Block,
 Ocean Centre, 5 Canton Rd.
 Tsimshatsui, Kowloon
 Hong Kong
 Tel: (852) 2737-1600
 Fax: (852) 2736-9960

National Semiconductor Japan Ltd.
 Tel: 81-043-299-2309
 Fax: 81-043-299-2408

National does not assume any responsibility for use of any circuitry described, no circuit patent licenses are implied and National reserves the right at any time without notice to change said circuitry and specifications.

This datasheet has been download from:

www.datasheetcatalog.com

Datasheets for electronics components.

National Semiconductor was acquired by Texas Instruments.

http://www.ti.com/corp/docs/investor_relations/pr_09_23_2011_national_semiconductor.html

This file is the datasheet for the following electronic components:

NM27P512 - <http://www.ti.com/product/nm27p512?HQS=TI-null-null-dscatalog-df-pf-null-ww>