

KM44C256/KM44C258

256K x 4 Bit CMOS Dynamic RAM

FEATURES

- Performance range:

	t _{RAC}	t _{CAC}	t _{RC}
KM44C256/8-10	100ns	25ns	190ns
KM44C256/8-12	120ns	35ns	220ns

- Fast Page Mode operation—KM44C256
- Static Column Mode operation—KM44C258
- CAS-before-RAS refresh
- RAS-only and Hidden refresh
- TTL compatible inputs and outputs
- Early Write or Output Enable Controlled Write
- Single +5V ± 10% power supply
- 512 cycles/8ms refresh
- JEDEC standard pinout
- Available in Plastic 20-pin DIP, SOJ or ZIP

GENERAL DESCRIPTION

The Samsung KM44C256/8 is a CMOS high speed 262,144 x 4 bit Dynamic Random Access Memory. Its design is optimized for high performance applications such as mainframes and mini computers, graphics and high performance microprocessor systems.

The KM44C256 features Fast Page Mode and the KM44C258 features Static Column Mode which allow high speed random access of memory cells within the same row. CAS-before-RAS refresh capability provides on-chip auto refresh as an alternative to RAS-only Refresh. All inputs and outputs are fully TTL compatible.

The KM44C256/8 is fabricated using Samsung's advanced CMOS process.

FUNCTIONAL BLOCK DIAGRAM

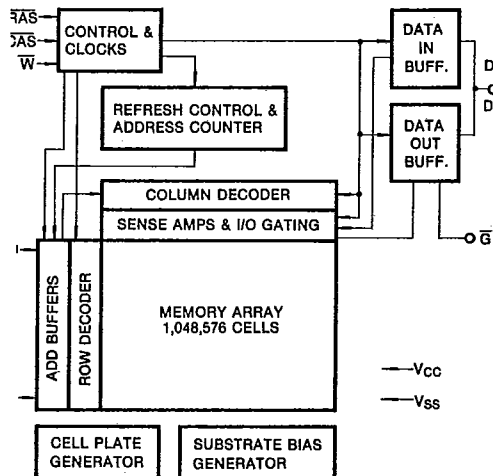

PIN CONFIGURATIONS

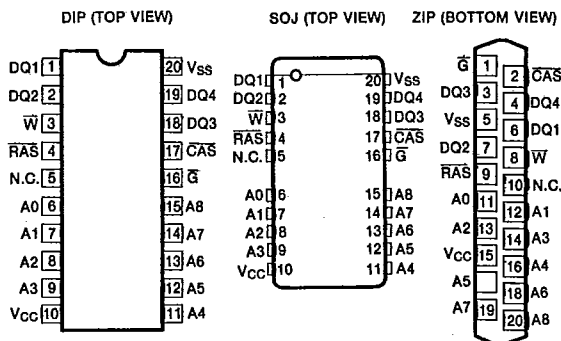

Pin Name	Pin Function
A ₀ -A ₉	Address Inputs
DQ1-DQ2	Data In/Data Out
\bar{W}	Read/Write Input
\bar{RAS}	Row Address Strobe
\bar{CAS}	Column Address Strobe
\bar{G}	Data Output Enable
V _{CC}	Power (+5V)
V _{SS}	Ground
N.C.	No connection